

# USER MANUAL

---

EMD200DP-T, EMD200DV-T, EMD2000PE-DP-T, EMD2000PE-R, EMD2000PE-R-P, EMD2000PE-T, EMD2000PE-T-P, EMD2000SE-DP-T, EMD2000SE-R, EMD2000SE-T, EMD2002PE-DP-T, EMD2002PE-R, EMD2002PE-R-P, EMD2002PE-T, EMD2002PE-T-P, EMD2002SE-DP-T, EMD2002SE-R, EMD2002SE-T, EMD2000SE-T-R2, EMD2000PE-T-R2, EMD2002PE-T-R2, EMD2000SE-DP-R, EMD2002SE-DP-R, EMD2000PE-DP-R, EMD2002PE-DP-R, EMD4000T, EMD4000R

# EMERALD KVM OVER IP TECHNOLOGY

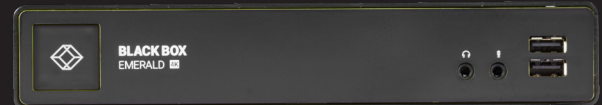
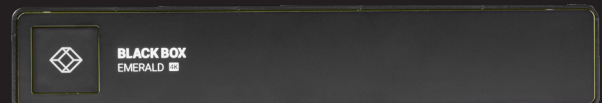

**BLACK BOX**  **X**<sup>®</sup>

# TABLE OF CONTENTS

<b>1. SPECIFICATIONS</b>	<b>5</b>
1.1 Specifications	5
1.2 Licensing	32
<b>2. OVERVIEW</b>	<b>33</b>
2.1 Emerald System Features	34
2.2 Overview of Emerald Devices	35
2.2.1 Video	36
2.2.2 Audio	36
2.2.3 Support for Keyboards, Mice, and USB Devices	36
2.2.4 IP Addressing	37
2.2.5 Firmware Upgrade	37
2.3 Application Examples	37
2.3.1 Video, Audio, and USB Extension	37
2.3.2 Video, Audio, and USB Switching	38
<b>3. CONFIGURATION</b>	<b>39</b>
3.1 Receiver Configuration	39
3.2 Transmitter Configuration	40
3.3 Boxilla Manager Configuration	41
<b>4. MODES OF OPERATION</b>	<b>42</b>
4.1 Auto-Login	42
4.2 Auto-Connect	42
4.3 Private Connection	42
4.4 Shared Connection	42
4.5 Video Source Optimization	42
<b>5. INSTALLATION</b>	<b>43</b>
5.1 Emerald Receiver (EMD2000SE-R, EMD2002SE-R, EMD2000PE-R, EMD2000PE-R-P, EMD2002PE-R, EMD2002PE-R-P) Checklist	43
5.2 Emerald Transmitter (EMD2000SE-T, EMD2002SE-T, EMD2000PE-T, EMD2000-PE-T-P, EMD2002PE-T, EMD2002-PE-T-P, EMD2000SE-T-R2, EMD2000PE-T-R2, EMD2002PE-T-R2) Checklist	43
5.3 Emerald SE or PE Transmitter Kit (EMD2000SE-T-K, EMD2002SE-T-K, EMD2000PE-K, and EMD2002PE-K) Checklist	43
5.4 Emerald ZeroU DVI or DP Transmitter (EMD200V-T or EMD200DP-T) Checklist	44
5.5 Emerald DisplayPort™ SE and PE Transmitters (EMD2000PE-DP-T, EMD2000SE-DP-T, EMD2002PE-DP-T, EMD2002SE-DP-T) Checklist	44
5.6 Emerald DisplayPort SE and PE Receivers (EMD2000SE-DP-R, EMD2002SE-DP-R, EMD2000PE-DP-R, EMD2002PE-DP-R) Checklist	44
5.7 Emerald 4K Transmitter (EMD4000T) Checklist	44
5.8 Emerald 4K Receiver (EMD4000R) Checklist	45
5.9 Installation Options	45



# TABLE OF CONTENTS

5.10 Connect the Emerald Receiver .....	46
5.10.1 Emerald SE Receiver Connector Information .....	47
5.10.2 Emerald SE DP Receiver Connector Information .....	49
5.10.3 Emerald PE or PoE Receiver Connector Information .....	51
5.10.4 Emerald PE Single-head DisplayPort Receiver Connector Information.....	53
5.10.5 Emerald PE Dual-head DisplayPort Receiver Connector Information.....	54
5.10.6 Emerald 4K Receiver Connector Information .....	55
5.11 Connect the Emerald Transmitter .....	57
5.11.1 Emerald ZeroU DVI and DP Connector Information.....	58
5.11.2 Emerald SE Transmitter Connector Information.....	60
5.11.3 Emerald SE R2 DVI Transmitter, Single-head Connector Information.....	62
5.11.4 Emerald SE Single-head DisplayPort Transmitter Connector Information.....	63
5.11.5 Emerald SE Dual-head DisplayPort Transmitter Connector Information.....	64
5.11.6 Emerald PE or PE PoE Transmitter Connector Information.....	65
5.11.7 Emerald PE R2 Single-head Transmitter Connector Information.....	67
5.11.8 Emerald PE R2 Dual-head Transmitter Connector Information .....	68
5.11.9 Emerald PE Single-head DisplayPort Transmitter Connector Information.....	69
5.11.10 Emerald PE Dual-head DisplayPort Transmitter Connector Information .....	70
5.11.11 Emerald 4K Transmitter Connector Information .....	71
5.12 Connect the Emerald ZeroU DVI or DisplayPort Transmitter .....	73
<b>6. NETWORKED INSTALLATION .....</b>	<b>74</b>
6.1 Point-to-Point Installation.....	74
6.2 Unmanaged or Managed Matrix Installation .....	74
<b>7. OPERATION OF EMERALD SYSTEM .....</b>	<b>75</b>
7.1 LED Identification .....	75
7.2 Accessing the System.....	75
<b>8. OSD FUNCTIONS .....</b>	<b>76</b>
8.1 User Types.....	76
8.2 Log On .....	76
8.3 Default Username and Password .....	77
8.4 User Views and Capabilities.....	78
8.5 Connections Screen.....	78
8.5.1 Idle Screen.....	79
8.5.2 Creating a New Connection.....	80
8.5.3 Connection Favorites .....	83
8.5.4 Connection Folders .....	85
8.5.5 Connecting .....	86
8.5.6 Edit Connection .....	86
8.5.7 Remove Connection .....	87



# TABLE OF CONTENTS

8.5.8 Bonding .....	87
8.6 Control Tab.....	88
8.6.1 Preferences .....	89
8.6.2 Network.....	95
8.6.3 System.....	96
8.7 USB Devices.....	106
8.8 Managing Users .....	108
8.8.1 Add a User .....	109
8.8.2 Auto Log-on .....	109
8.8.3 Edit a User .....	110
8.8.4 Remove a User .....	111
8.9 LACP .....	112
<b>APPENDIX A. EMERALD VIDEO RESOLUTIONS SUPPORTED .....</b>	<b>113</b>
<b>APPENDIX B. EMERALD 4K MODELS .....</b>	<b>114</b>
B.1 Compatible Rackmount Kits .....	114
B.2 Compatible Network Switches .....	114
B.3 Comparison Chart.....	115
B.4 Compatible SFPS .....	115
B.5 Compatible Cables.....	115
B.6 Guidelines for System Hardening for an Emerald Deployment .....	116
<b>APPENDIX C. NETWORK REQUIREMENTS AND PORT USAGE.....</b>	<b>120</b>
C.1 Recommended Network Design .....	120
C.2 Multi-Subnet Support .....	120
C.3 4K Multicast Support.....	120
C.4 TCP/UDP Port Usage.....	123
C.5 Network Switch Requirements .....	124
<b>APPENDIX D. CONFIGURING WINDOWS 10 VIRTUAL MACHINES.....</b>	<b>125</b>
<b>APPENDIX E. EMERALD NETWORK PROTOCOLS OVERVIEW.....</b>	<b>126</b>
<b>APPENDIX F. TROUBLESHOOTING .....</b>	<b>127</b>
<b>APPENDIX G. REGULATORY INFORMATION .....</b>	<b>129</b>
G.1 FCC Statement .....	129
G.2 NOM Statement .....	130
<b>APPENDIX H. TECH SUPPORT/DISCLAIMERS/TRADEMARKS.....</b>	<b>131</b>
H.1 Tech Support/Contact Information .....	131
H.2 Disclaimers .....	131
H.3 Trademarks Used in this Manual.....	131



# CHAPTER 1: SPECIFICATIONS

## 1.1 SPECIFICATIONS

### EMERALD ZEROU DVI TRANSMITTER (EMD200DV-T)

TRANSMITTER



NOTE: The Emerald® ZeroU DVI transmitter (EMD200DV-T) supports speakers-only audio on the 3.5-mm connector.

### WHAT'S INCLUDED WITH THE TRANSMITTER (EMD200DV-T)

- ♦ (1) EMERALD ZEROU DVI TRANSMITTER

NOTE: The EMD200DV-T does not support USB-redirected connections or devices.

### SPECIFICATIONS FOR EMERALD ZEROU DVI TRANSMITTER (EMD200DV-T)

APPROVALS	
UNIT	Directive 2014/30/EU, CE, FCC, UKCA, 2011/65/EU, 2015/863/EU, Reach, TSCA, CB
PHYSICAL	
LED INTERFACE	(1) Power LED (green); (1) RJ-45 Speed LED (green, located on top left of RJ-45 connector): Blinks three times when the network connection is 1000 Mbps, Blinks two times when network connection is 100 Mbps, Blinks once when the network connection is 10 Mbps, Not blinking: No link to network; (1) Activity LED (green, located on top right of RJ-45 connector): Solid green: Link up, Blinking: Activity on the link, OFF: No link
MAXIMUM DISTANCE FROM CPU TO TRANSMITTER	12" (305 mm) via connected cable harness
MAXIMUM DISTANCE BETWEEN TRANSMITTER AND RECEIVER	328 ft. (100 m), use a network switch to get farther distances
OPERATING SYSTEM SUPPORT	Microsoft Windows® 10/11, Server OS, Linux®, and Mac OS
CONNECTORS	(1) DVI input, (2) USB Type A female, (1) RJ-45 network (10/100/1000BASE-T), (1) 2.5-mm barrel for power; NOTE: The ZeroU transmitter can be powered via (2) USB Type A connectors or via an optional DC power adapter.
DIMENSIONS	0.98" H x 2.78" W x 6.12" D (25 x 71 x 155 mm)
WEIGHT	0.48 lb. (221 g)
OPERATION	
DEFAULT IP ADDRESS	192.168.1.22
ENCRYPTION	Secure Sockets Layer (SSL) over TCP/IP, 128-bit between transmitter and receiver
DDC SUPPORT	Built-in/clone of remote
POWER	
POWER SOURCE	Via USB or an optional 5VDC power adapter
INPUT VOLTAGE	5VDC
ENVIRONMENTAL	
OPERATING TEMPERATURE	32 to 104° F (0 to 40° C)
STORAGE TEMPERATURE	-4 to +140° F (-20 to 60° C)
OPERATING HUMIDITY	5 to 95%, noncondensing
HEAT DISSIPATION	8.52 BTU/h maximum



# CHAPTER 1: SPECIFICATIONS

## EMERALD ZEROU DISPLAYPORT TRANSMITTER (EMD200DP-T) TRANSMITTER

The Emerald® system will take audio from your DisplayPort™ connector and transmit it across the network just like it does with the video signal. The receiver will decode this and send it out the receiver's 3.5-mm audio connector with no configuration required in Emerald.

NOTE: The graphics card and OS must support embedded audio over DisplayPort, and it may need to be enabled on your system.



NOTE: The Emerald ZeroU DisplayPort transmitter (EMD200DP-T) supports embedded audio on the DisplayPort connector.

## WHAT'S INCLUDED WITH THE TRANSMITTER (EMD200DP-T)

- ♦ (1) EMERALD ZEROU DISPLAYPORT TRANSMITTER

NOTE: The EMD200DP-T cannot support USB-redirected connections.

### SPECIFICATIONS FOR EMERALD ZEROU DISPLAYPORT TRANSMITTER (EMD200DP-T)

APPROVALS	
UNIT	Directive 2014/30/EU, CE, FCC, UKCA, 2011/65/EU, 2015/863/EU, Reach, TSCA, CB
PHYSICAL	
LED INTERFACE	(1) Power LED (green); (1) RJ-45 Speed LED (green, located on top left of RJ-45 connector): Blinks three times when the network connection is 1000 Mbps, Blinks two times when network connection is 100 Mbps, Blinks once when the network connection is 10 Mbps, Not blinking: No link to network; (1) Activity LED (green, located on top right of RJ-45 connector): Solid green: Link up, Blinking: Activity on the link, OFF: No link
MAXIMUM DISTANCE FROM CPU TO TRANSMITTER	12" (305 mm) via connected cable harness
MAXIMUM DISTANCE BETWEEN TRANSMITTER AND RECEIVER	328 ft. (100 m), use a network switch to get farther distances
OPERATING SYSTEM SUPPORT	Microsoft Windows® 10/11, Server OS, Linux®, and Mac OS
CONNECTORS	(1) DisplayPort input, (2) USB Type A female, (1) RJ-45 network (10/100/1000BASE-T), (1) 2.5-mm barrel for power; NOTE: The ZeroU transmitter can be powered via (2) USB Type A connectors or via an optional DC power adapter.
DIMENSIONS	0.98" H x 2.78" W x 6.12" D (25 x 71 x 155 mm)
WEIGHT	0.43 lb. (198 g)
OPERATION	
DEFAULT IP ADDRESS	192.168.1.22
ENCRYPTION	Secure Sockets Layer (SSL) over TCP/IP, 128-bit between transmitter and receiver
DDC SUPPORT	Built-in/clone of remote
POWER	
POWER SOURCE	Via USB or an optional 5VDC power adapter
INPUT VOLTAGE	5VDC
ENVIRONMENTAL	
OPERATING TEMPERATURE	32 to 104° F (0 to 40° C)
STORAGE TEMPERATURE	-4 to +140° F (-20 to 60° C)
OPERATING HUMIDITY	5 to 95%, noncondensing
HEAT DISSIPATION	8.52 BTU/h maximum



# CHAPTER 1: SPECIFICATIONS

## EMERALD PE SINGLE-HEAD TRANSMITTER (EMD2000PE-T, EMD2000PE-T-P) AND RECEIVER (EMD2000PE-R, EMD2000PE-R-P)

TRANSMITTER FRONT VIEW



RECEIVER FRONT VIEW



TRANSMITTER BACK VIEW



RECEIVER BACK VIEW



### WHAT'S INCLUDED WITH THE TRANSMITTER (EMD2000PE-T\* OR EMD2000PE-T-P\*)

- (1) EMERALD PE TRANSMITTER, SINGLE-HEAD
- (1) 12VDC POWER SUPPLY WITH POWER CORD
- (1) DVI CABLE
- (1) USB 2.0 TYPE B CABLE

\* EMD2000PE-T IS EOL. IT IS REPLACED BY EMD2000PE-T-R2.

EMD2000PE-T-R IS EOL. IT IS REPLACED BY EMD2000PE-T-R2.

### WHAT'S INCLUDED WITH THE RECEIVER (EMD2000PE-R\* OR EMD2000PE-R-P)

- (1) EMERALD PE RECEIVER, SINGLE-HEAD
- (1) 12VDC POWER SUPPLY WITH POWER CORD

\* EMD2000PE-R IS EOL. USE EMD2000PE-R-P.

# CHAPTER 1: SPECIFICATIONS

## SPECIFICATIONS FOR EMERALD PE TRANSMITTER AND RECEIVER, SINGLE-HEAD (EMD2000PE-T, EMD2000PE-T-P, EMD2000PE-R, EMD2000PE-R-P)

APPROVALS	
UNIT	Directive 2014/30/EU, CE, FCC, ICES, UKCA, 2011/65/EU, 2015/863/EU, Reach, TSCA, CB
POWER SUPPLY	Directive 2014/35/EU, EN 62368-1:2014, UL, cUL, GS, PSE, BSMI, RCM, BIS, CB
PHYSICAL	
LED INTERFACE	<p>(1) Power LED (lights when power is on); NOTE: Unit automatically powers on when plugged in; must be powered off at the power source.</p> <p>(1) RJ-45 Speed LED (green, located on top left of RJ-45 connector): Blinks three times when the network connection is 1000 Mbps, Blinks two times when network connection is 100 Mbps, Blinks once when the network connection is 10 Mbps, Not blinking: No link to network;</p> <p>(1) Activity LED (green, located on top right of RJ-45 connector): Solid green: Link up, Blinking: Activity on the link, OFF: No link</p>
MAXIMUM DISTANCE FROM CPU TO TRANSMITTER	5 m (16.4 ft.), DVI-D and USB limitations
MAXIMUM DISTANCE BETWEEN TRANSMITTER AND RECEIVER	328 ft. (100 m), use a network switch to get farther distances
OPERATING SYSTEM SUPPORT	Microsoft Windows® 10/11, Server OS, Linux®, and Mac OS
CONNECTORS	<p>EMD2000PE-T: (1) DVI input, (1) USB Type B female, (1) RJ-45 network, (1) SFP network, (2) 3.5-mm audio, (1) 3-pin locking connector for power, (1) Micro USB connector;</p> <p>EMD2000PE-T-P: (1) DVI input, (1) USB Type B female, (1) RJ-45 PoE network, (1) SFP network, (2) 3.5-mm audio, (1) 3-pin locking connector for power, (1) Micro USB connector;</p> <p>EMD2000PE-R: (1) DVI output, (4) USB Type A female, (1) RJ-45 network, (1) SFP network, (2) 3.5-mm audio for SPK and MIC, (1) 3-pin locking connector for power, (1) Micro USB connector;</p> <p>EMD2000PE-R-P: (1) DVI output, (4) USB Type A female, (1) RJ-45 PoE network, (1) SFP network, (2) 3.5-mm audio for SPK and MIC, (1) 3-pin locking connector for power, (1) Micro USB connector</p>
DIMENSIONS	1.32" H x 7.62" W x 5.79" D (34 x 194 x 147 mm)
WEIGHT	EMD2000PE-T/EMD2000PE-T-R: 1.08 lbs (490 g); EMD2000PE-R/EMD2000PE-R-P: 1.17 lbs (535 g)
OPERATION	
DEFAULT IP ADDRESS	EMD2000PE-T, EMD2000PE-T-P: 192.168.1.22; EMD2000PE-R, EMD2000PE-R-P: 192.168.1.21
ENCRYPTION	Secure Sockets Layer (SSL) over TCP/IP, 128-bit between transmitter and receiver, user set between receiver and virtual machine
DEFAULT USERNAME	admin
DEFAULT PASSWORD	The password is blank by default.
DDC SUPPORT	Built-in/clone of remote
POWER	
POWER SOURCE	External in-line power supply or PoE IEEE 802.11af (EMD2000PE-T-P, EMD2000PE-R-P only)
INPUT VOLTAGE	100–240 VAC, 50/60 Hz
INPUT CURRENT	1 Amp maximum
POWER CONSUMPTION	Unit: 7.5 W with keyboard and mouse attached; Power supply: 36 W to support USB-based powered devices
HEAT DISSIPATION	122.76 BTW/hr maximum
OUTPUT CONNECTOR	3-pin locking connector (12 VDC, 3 Amp output)
INPUT CONNECTOR	IEC-320, C14
POWER SUPPLY CORD LENGTH	6 ft. (1.8 m)
ENVIRONMENTAL	
OPERATING TEMPERATURE	32 to 104° F (0 to 40° C)
STORAGE TEMPERATURE	-4 to +140° F (-20 to 60° C)
OPERATING HUMIDITY	5 to 95%, noncondensing



# CHAPTER 1: SPECIFICATIONS

EMERALD PE DUAL-HEAD TRANSMITTER (EMD2002PE-T, EMD2002PE-T-P)  
AND RECEIVER (EMD2002PE-R, EMD2002PE-R-P)

TRANSMITTER FRONT VIEW



RECEIVER FRONT VIEW



TRANSMITTER BACK VIEW



RECEIVER BACK VIEW



## WHAT'S INCLUDED WITH THE TRANSMITTER (EMD2002PE-T\*, EMD2002PE-T-P)

- ♦ (1) EMERALD PE TRANSMITTER, DUAL-HEAD
- ♦ (1) 12VDC POWER SUPPLY WITH POWER CORD
- ♦ (2) DVI CABLES
- ♦ (1) USB 2.0 TYPE B CABLE

## WHAT'S INCLUDED WITH THE RECEIVER (EMD2002PE-R\* OR EMD2002PE-R-P)

- ♦ (1) EMERALD PE RECEIVER, DUAL-HEAD
- ♦ (1) 12VDC POWER SUPPLY WITH POWER CORD

\* EMD2002PE-R IS EOL. USE EMD2002PE-R-P.

\* EMD2002PE-T IS EOL. IT IS REPLACED BY EMD20002PE-T-R2.  
EMD2002PE-T-R IS EOL. IT IS REPLACED BY EMD2002PE-T-R2.

# CHAPTER 1: SPECIFICATIONS

## SPECIFICATIONS FOR EMERALD PE TRANSMITTER AND RECEIVER, DUAL-HEAD (EMD2002PE-T, EMD2002-PE-T-P, EMD2002PE-R, EMD2002PE-R-P)

APPROVALS	
UNIT	Directive 2014/30/EU, CE, FCC, ICES, UKCA, 2011/65/EU, 2015/863/EU, Reach, TSCA, CB
POWER SUPPLY	Directive 2014/35/EU, EN 62368-1:2014, UL, cUL, GS, PSE, BSMI, RCM, BIS, CB
PHYSICAL	
LED INTERFACE	(1) Power LED (lights when power is on); NOTE: Unit automatically powers on when plugged in; must be powered off at the power source. (1) RJ-45 Speed LED (green, located on top left of RJ-45 connector): Blinks three times when the network connection is 1000 Mbps, Blinks two times when network connection is 100 Mbps, Blinks once when the network connection is 10 Mbps, Not blinking: No link to network; (1) Activity LED (green, located on top right of RJ-45 connector): Solid green: Link up, Blinking: Activity on the link, OFF: No link
MAXIMUM DISTANCE FROM CPU TO TRANSMITTER	5 m (16.4 ft.), DVI-D and USB limitations
MAXIMUM DISTANCE BETWEEN TRANSMITTER AND RECEIVER	328 ft. (100 m), use a network switch to get farther distances
OPERATING SYSTEM SUPPORT	Microsoft Windows® 10/11, Server OS, Linux®, and Mac OS
CONNECTORS	EMD2002PE-T: (2) DVI inputs, (1) USB Type B female, (1) RJ-45 network, (1) SFP network, (2) 3.5-mm audio, (1) 3-pin locking connector for power, (1) Micro USB connector; EMD2002PE-T-P: (2) DVI inputs, (1) USB Type B female, (1) RJ-45 PoE network, (1) SFP network, (2) 3.5-mm audio, (1) 3-pin locking connector for power, (1) Micro USB connector; EMD2002PE-R: (2) DVI outputs, (4) USB Type A female, (1) RJ-45 network, (1) SFP network, (2) 3.5-mm audio for SPK and MIC, (1) 3-pin locking connector for power, (1) Micro USB connector; EMD2002PE-R-P: (2) DVI outputs, (4) USB Type A female, (1) RJ-45 PoE network, (1) SFP network, (2) 3.5-mm audio for SPK and MIC, (1) 3-pin locking connector for power, (1) Micro USB connector
DIMENSIONS	1.32" H x 7.62" W x 5.79" D (34 x 194 x 147 mm)
WEIGHT	EMD2002PE-T: 1.10 lbs (503 g); EMD2002PE-R / EMD2002PE-R-P: 1.47 lbs (667 g)
OPERATION	
DEFAULT IP ADDRESS	EMD2002PE-T, EMD2002PE-T-P: 192.168.1.22; EMD2002PE-R, EMD2002PE-R-P: 192.168.1.21
ENCRYPTION	Secure Sockets Layer (SSL) over TCP/IP, 128-bit between transmitter and receiver, user set between receiver and virtual machine
DEFAULT USERNAME	admin
DEFAULT PASSWORD	The password is blank by default.
DDC SUPPORT	Built-in/clone of remote
POWER	
POWER SOURCE	External in-line power supply or PoE IEEE 802.11af (EMD2000PE-T-P, EMD2000PE-R-P only)
INPUT VOLTAGE	100–240 VAC, 50/60 Hz
INPUT CURRENT	1 Amp maximum
POWER CONSUMPTION	Unit: 7.5 W with keyboard and mouse attached; Power supply: 36 W to support USB-based powered devices
HEAT DISSIPATION	122.76 BTW/hr maximum
OUTPUT CONNECTOR	3-pin locking connector (12 VDC, 3 Amp output)
INPUT CONNECTOR	IEC-320, C14
POWER SUPPLY CORD LENGTH	6 ft. (1.8 m)
ENVIRONMENTAL	
OPERATING TEMPERATURE	32 to 104° F (0 to 40° C)
STORAGE TEMPERATURE	-4 to +140° F (-20 to 60° C)
OPERATING HUMIDITY	5 to 95%, noncondensing



# CHAPTER 1: SPECIFICATIONS

## EMERALD PE SINGLE-HEAD DISPLAYPORT TRANSMITTER (EMD2000PE-DP-T) AND RECEIVER (EMD2000PE-DP-R)

TRANSMITTER FRONT VIEW



TRANSMITTER BACK VIEW



RECEIVER FRONT VIEW



RECEIVER BACK VIEW



### WHAT'S INCLUDED WITH THE TRANSMITTER (EMD2000PE-DP-T)

- (1) EMERALD PE DP TRANSMITTER, SINGLE-HEAD
- (1) 12VDC POWER SUPPLY WITH POWER CORD
- (1) DISPLAYPORT™ CABLE
- (1) USB TYPE A TO B CABLE

### WHAT'S INCLUDED WITH THE RECEIVER (EMD2000PE-DP-R)

- (1) EMERALD PE DP RECEIVER, SINGLE-HEAD
- (1) 12VDC POWER SUPPLY WITH POWER CORD

# CHAPTER 1: SPECIFICATIONS

## SPECIFICATIONS FOR EMERALD PE DISPLAYPORT TRANSMITTER, SINGLE -HEAD (EMD2000PE-DP-T), AND RECEIVER (EMD2000PE-DP-R)

APPROVALS	
UNIT	Directive 2014/30/EU, CE, FCC, UKCA, 2011/65/EU, 2015/863/EU, Reach, TSCA
POWER SUPPLY	Directive 2014/35/EU, EN 62368-1:2014, UL, cUL, GS, PSE, BSMI, RCM, BIS, CB
PHYSICAL	
LED INTERFACE	(1) Power LED; (1) Network LED; (1) Video 1 Status LED; (1) RJ-45 Speed LED (green, located on top left of RJ-45 connector): Blinks three times when the network connection is 1000 Mbps, Blinks two times when network connection is 100 Mbps, Blinks once when the network connection is 10 Mbps, Not blinking: No link to network; (1) Activity LED (green, located on top right of RJ-45 connector): Solid green: Link up, Blinking: Activity on the link, OFF: No link
MAXIMUM DISTANCE FROM CPU TO TRANSMITTER	5 m (16.4 ft.), DisplayPort™ and USB limitations
MAXIMUM DISTANCE BETWEEN TRANSMITTER AND RECEIVER	328 ft. (100m) CATx Fiber: Distance dependent on SFP and Fiber cable used
OPERATING SYSTEM SUPPORT	Microsoft Windows® 10/11, Server OS, Linux®, and Mac OS
CONNECTORS	EMD2000PE-DP-T: (1) DisplayPort female, (1) USB Type B female, (1) 3.5-mm audio, (1) RJ-45 Interconnect, 1Gbps, (1) SFP Interconnect, 1 Gbps (unpopulated), (1) USB Type B micro (Console), (1) 3-pin locking connector for power (12VDC); EMD2000PE-DP-R: (1) DisplayPort female, (4) USB Type A female, (1) 3.5-mm audio, (1) RJ-45 Interconnect, (1) SFP Interconnect 1Gbps (unpopulated), (1) USB Type B Micro (Console), (2) Power Inputs; (1) 3-pin locking power connector for power (12VDC)
DIMENSIONS	EMD2000PE-DP-T: 1.34" H x 5.39" W x 6.1" D (34 x 137 x 155 mm); EMD2000PE-DP-R: 1.3" H x 7.62" W x 5.81" D (33.11 x 193.6 x 147.8mm)
WEIGHT	EMD2000PE-DP-T: 0.84 lbs (382 g); EMD2000PE-DP-R: 0.85 lbs (384 g)
OPERATION	
DEFAULT IP ADDRESS	EMD2000PE-DP-T: 192.168.1.22; EMD2000PE-DP-R: 192.168.1.21
ENCRYPTION	Secure Sockets Layer (SSL) over TCP/IP, 128-bit between transmitter and receiver, user set between receiver and virtual machine
DDC SUPPORT	Built-in/clone of remote
POWER	
POWER SOURCE	External in-line power supply
INPUT VOLTAGE	100–240 VAC, 50/60 Hz
INPUT CURRENT	1 Amp maximum
POWER CONSUMPTION	36 W maximum (Unit consumes 9 W)
HEAT DISSIPATION	122.76 BTW/hr maximum
OUTPUT CONNECTOR	3-pin locking connector (12 VDC, 3 Amp output)
INPUT CONNECTOR	IEC320, C14
POWER SUPPLY CORD LENGTH	6 ft. (1.8 m)
ENVIRONMENTAL	
OPERATING TEMPERATURE	32 to 104° F (0 to 40° C)
STORAGE TEMPERATURE	-4 to +140° F (-20 to 60° C)
OPERATING HUMIDITY	5 to 95%, noncondensing



# CHAPTER 1: SPECIFICATIONS

## EMERALD PE DUAL-HEAD DISPLAYPORT TRANSMITTER (EMD2002PE-DP-T) AND RECEIVER (EMD2002PE-DP-R)

TRANSMITTER FRONT VIEW



TRANSMITTER BACK VIEW



RECEIVER FRONT VIEW



RECEIVER BACK VIEW



### WHAT'S INCLUDED WITH THE TRANSMITTER (EMD2002PE-DP-T)

- (1) EMERALD PE DP TRANSMITTER, DUAL-HEAD
- (1) 12VDC POWER SUPPLY WITH POWER CORD
- (2) DISPLAYPORT™ CABLES
- (1) USB TYPE A TO B CABLE

### WHAT'S INCLUDED WITH THE RECEIVER (EMD2002PE-DP-R)

- (1) EMERALD PE DP RECEIVER, DUAL-HEAD
- (1) 12VDC POWER SUPPLY WITH POWER CORD

# CHAPTER 1: SPECIFICATIONS

SPECIFICATIONS FOR EMERALD PE DISPLAYPORT TRANSMITTER, DUAL-HEAD (EMD2002PE-DP-T)	
<b>APPROVALS</b>	
<b>UNIT</b>	Directive 2014/30/EU, CE, FCC, UKCA, 2011/65/EU, 2015/863/EU, Reach, TSCA
<b>POWER SUPPLY</b>	Directive 2014/35/EU, EN 62368-1:2014, UL, cUL, GS, PSE, BSMI, RCM, BIS, CB
<b>PHYSICAL</b>	
<b>LED INTERFACE</b>	(1) Power LED; (1) Network LED; (1) Video 1 Status LED; (1) Video 2 Status LED; (1) RJ-45 Speed LED (green, located on top left of RJ-45 connector): Blinks three times when the network connection is 1000 Mbps, Blinks two times when network connection is 100 Mbps, Blinks once when the network connection is 10 Mbps, Not blinking: No link to network; (1) Activity LED (green, located on top right of RJ-45 connector): Solid green: Link up, Blinking: Activity on the link, OFF: No link
<b>MAXIMUM DISTANCE FROM CPU TO TRANSMITTER</b>	5 m (16.4 ft.), DisplayPort™ and USB limitations
<b>MAXIMUM DISTANCE BETWEEN TRANSMITTER AND RECEIVER</b>	328 ft. (100m) CATx Fiber: Distance dependent on SFP and Fiber cable used
<b>OPERATING SYSTEM SUPPORT</b>	Microsoft Windows® 10/11, Server OS, Linux®, and Mac OS
<b>CONNECTORS</b>	EMD2002PE-DP-T: (2) DisplayPort female, (1) USB Type B female, (1) 3.5-mm audio, (1) RJ-45 Interconnect, 1Gbps, (1) SFP Interconnect, 1 Gbps (unpopulated), (1) USB Type B micro (Console), (1) 3-pin locking connector for power (12VDC); EMD2002PE-DP-R: (2) DisplayPort female, (4) USB Type A female, (1) 3.5-mm audio, (1) RJ-45 Interconnect, 1Gbps, (1) SFP Interconnect, 1 Gbps (unpopulated), (1) USB Type B micro (Console), (2) Power inputs; (1) 3-pin locking connector for power (12VDC)
<b>DIMENSIONS</b>	EMD2002PE-DP-T: 1.34" H x 5.39" W x 6.1" D (34 x 137 x 155 mm); EMD2002PE-DP-R: 1.3" H x 7.62" W x 5.81" D (33.11 x 193.6 x 147.8mm)
<b>WEIGHT</b>	EMD2002PE-DP-T: 0.85 lbs (387 g); EMD2002PE-DP-R: 0.85 lbs (385 g)
<b>OPERATION</b>	
<b>DEFAULT IP ADDRESS</b>	EMD2002PE-DP-T: 192.168.1.22; EMD2002PE-DP-R: 192.168.1.21
<b>ENCRYPTION</b>	Secure Sockets Layer (SSL) over TCP/IP, 128-bit between transmitter and receiver, user set between receiver and virtual machines
<b>DDC SUPPORT</b>	Built-in/clone of remote
<b>POWER</b>	
<b>POWER SOURCE</b>	External in-line power supply
<b>INPUT VOLTAGE</b>	100–240 VAC, 50/60 Hz
<b>INPUT CURRENT</b>	1 Amp maximum
<b>POWER CONSUMPTION</b>	36 W maximum (Unit consumes 9.5 W)
<b>HEAT DISSIPATION</b>	122.76 BTW/hr maximum
<b>OUTPUT CONNECTOR</b>	3-pin locking connector (12 VDC, 3 Amp output)
<b>INPUT CONNECTOR</b>	IEC320, C14
<b>POWER SUPPLY CORD LENGTH</b>	6 ft. (1.8 m)
<b>ENVIRONMENTAL</b>	
<b>OPERATING TEMPERATURE</b>	32 to 104° F (0 to 40° C)
<b>STORAGE TEMPERATURE</b>	-4 to +140° F (-20 to 60° C)
<b>OPERATING HUMIDITY</b>	5 to 95%, noncondensing



# CHAPTER 1: SPECIFICATIONS

## EMERALD SE SINGLE-HEAD TRANSMITTER (EMD2000SE-T) AND RECEIVER (EMD2000SE-R)

TRANSMITTER FRONT VIEW



RECEIVER FRONT VIEW



TRANSMITTER BACK VIEW



RECEIVER BACK VIEW

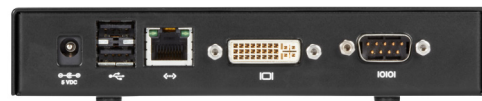

### WHAT'S INCLUDED WITH THE TRANSMITTER (EMD2000SE-T\*)

- (1) EMERALD SE TRANSMITTER, SINGLE-HEAD
- (1) 5VDC POWER SUPPLY WITH POWER CORD

### WHAT'S INCLUDED WITH THE RECEIVER (EMD2000SE-R)

- (1) EMERALD SE RECEIVER, SINGLE-HEAD
- (1) 5VDC POWER SUPPLY WITH POWER CORD

\* EMD2000SE-T IS EOL. IT IS REPLACED BY EMD2000SE-T-R2.

# CHAPTER 1: SPECIFICATIONS

## SPECIFICATIONS FOR EMERALD SE TRANSMITTER AND RECEIVER, SINGLE-HEAD (EMD2000SE-T AND EMD2000SE-R)

APPROVALS	
UNIT	Directive 2014/30/EU, CE, FCC, UKCA, 2011/65/EU, 2015/863/EU, Reach, TSCA, CB
POWER SUPPLY	Directive 2014/35/EU, EN 62368-1:2014, UL, cUL, GS, PSE, BSMI, RCM, BIS
PHYSICAL	
LED INTERFACE	(1) Power LED/button; NOTE: Unit automatically powers on when plugged in; must be powered off at the power source. (1) RJ-45 Speed LED (green, located on top left of RJ-45 connector): Blinks three times when the network connection is 1000 Mbps, Blinks two times when network connection is 100 Mbps, Blinks once when the network connection is 10 Mbps, Not blinking: No link to network; (1) Activity LED (green, located on top right of RJ-45 connector): Solid green: Link up, Blinking: Activity on the link, OFF: No link
MAXIMUM DISTANCE FROM CPU TO TRANSMITTER	5 m (16.4 ft.), DVI-D and USB limitations
MAXIMUM DISTANCE BETWEEN TRANSMITTER AND RECEIVER	328 ft. (100 m), use a network switch to get farther distances
OPERATING SYSTEM SUPPORT	Microsoft Windows® 10/11, Server OS, Linux®, and Mac OS
CONNECTORS	EMD2000SE-T: (1) DVI input, (1) USB Type B female, (1) RJ-45 network (10/100/1000BASE-T), (1) RJ-45 serial, (2) 3.5-mm audio, (1) 2.5-mm barrel for power; EMD2000SE-R: (1) DVI output, (4) USB Type A female, (1) RJ-45 network (10/100/1000BASE-T), (1) DB9 serial, (2) 3.5-mm audio for SPK and MIC, (1) 2.5-mm barrel for power
DIMENSIONS	1.15" H x 6.2" W x 4.2" D (29 x 157 x 107 mm)
WEIGHT	EMD2000SE-T: 1.30 lbs (590 g); EMD2000SE-R: 1.32 lbs (600 g)
OPERATION	
DEFAULT IP ADDRESS	EMD2000SE-T: 192.168.1.22; EMD2000SE-R: 192.168.1.21
ENCRYPTION	Secure Sockets Layer (SSL) over TCP/IP, 128-bit between transmitter and receiver, user set between receiver and virtual machine
DEFAULT USERNAME	admin
DEFAULT PASSWORD	The password is blank by default.
DDC SUPPORT	Built-in/clone of remote
POWER	
POWER SOURCE	External in-line power supply
INPUT VOLTAGE	100–240 VAC, 50/60 Hz
INPUT CURRENT	0.9 Amps maximum
POWER CONSUMPTION	Unit: 6.5 W with keyboard and mouse attached; Power supply: 20 W to support USB-based powered devices
HEAT DISSIPATION	68.2 BTW/hr maximum
OUTPUT CONNECTOR	2.5-mm barrel (5 VDC, 4 Amp output)
INPUT CONNECTOR	IEC-320, C8
POWER SUPPLY CORD LENGTH	6 ft. (1.8 m)
ENVIRONMENTAL	
OPERATING TEMPERATURE	32 to 104° F (0 to 40° C)
STORAGE TEMPERATURE	-4 to +140° F (-20 to 60° C)
OPERATING HUMIDITY	5 to 95%, noncondensing



# CHAPTER 1: SPECIFICATIONS

## EMERALD SE SINGLE-HEAD TRANSMITTER (EMD2000SE-T-R2)

EMD2000SE-T-R2 FRONT VIEW



EMD2000SE-T-R2- BACK VIEW



### WHAT'S INCLUDED WITH THE SINGLE-HEAD TRANSMITTER (EMD2000SE-T-R2)

- (1) EMERALD SE-R2 TRANSMITTER
- (1) 5VDC POWER SUPPLY WITH POWER CORD

# CHAPTER 1: SPECIFICATIONS

## SPECIFICATIONS FOR EMERALD SE SINGLE-HEAD TRANSMITTER (EMD2000SE-T-R2)

APPROVALS	
UNIT	Directive 2014/30/EU, CE, FCC, UKCA, 2011/65/EU, 2015/863/EU, Reach, TSCA
POWER SUPPLY	Directive 2014/35/EU, EN 62368-1:2014, UL, cUL, GS, PSE, BSMI, RCM, BIS
PHYSICAL	
LED INTERFACE	(1) Power LED; (1) Network LED; (1) Video 1 Status LED; (1) RJ-45 Speed LED (green, located on top left of RJ-45 connector): Blinks three times when the network connection is 1000 Mbps, Blinks two times when network connection is 100 Mbps, Blinks once when the network connection is 10 Mbps, Not blinking: No link to network; (1) Activity LED (green, located on top right of RJ-45 connector): Solid green: Link up, Blinking: Activity on the link, OFF: No link
MAXIMUM DISTANCE FROM CPU TO TRANSMITTER	5 m (16.4 ft.), DVI-D and USB limitations
MAXIMUM DISTANCE BETWEEN TRANSMITTER AND RECEIVER	328 ft. (100 m), use a network switch to get farther distances
OPERATING SYSTEM SUPPORT	Microsoft Windows® 10/11, Server OS, Linux®, and Mac OS
CONNECTORS	(1) DVI-D female, (1) USB Type B female, (1) 3.5-mm audio; (1) RJ-45 Interconnect, 1Gbps, (1) USB Type B micro (Console), (1) 2.5-mm barrel connector for power
DIMENSIONS	1.34" H x 6.1" W x 6.07" D (34 x 137 x 155 mm)
WEIGHT	0.78 lb. (355 g)
OPERATION	
DEFAULT IP ADDRESS	192.168.1.22
ENCRYPTION	Secure Sockets Layer (SSL) over TCP/IP, 128-bit between transmitter and receiver, user set between receiver and virtual machine
DDC SUPPORT	Built-in/clone of remote
POWER	
POWER SOURCE	External in-line power supply
INPUT VOLTAGE	100–240 VAC, 50/60 Hz
INPUT CURRENT	0.9 Amps maximum
POWER CONSUMPTION	Unit: 6.5 W with keyboard and mouse attached Power supply: 20 W to support USB-based powered devices
HEAT DISSIPATION	68.2 BTW/hr maximum
OUTPUT CONNECTOR	2.5-mm barrel (5 VDC, 4 Amp output)
INPUT CONNECTOR	IEC-320, C8
POWER SUPPLY CORD LENGTH	6 ft. (1.8 m)
ENVIRONMENTAL	
OPERATING TEMPERATURE	32 to 104° F (0 to 40° C)
STORAGE TEMPERATURE	-4 to +140° F (-20 to 60° C)
OPERATING HUMIDITY	5 to 95%, noncondensing



# CHAPTER 1: SPECIFICATIONS

## EMERALD SE DUAL-HEAD TRANSMITTER (EMD2002SE-T) AND RECEIVER (EMD2002SE-R)

TRANSMITTER FRONT VIEW



RECEIVER FRONT VIEW



TRANSMITTER BACK VIEW



RECEIVER BACK VIEW



### WHAT'S INCLUDED WITH THE TRANSMITTER (EMD2002SE-T\*)

- ♦ (1) EMERALD SE TRANSMITTER, DUAL-HEAD
- ♦ (1) 5VDC POWER SUPPLY WITH POWER CORD

### WHAT'S INCLUDED WITH THE RECEIVER (EMD2002SE-R)

- ♦ (1) EMERALD SE RECEIVER, DUAL-HEAD
- ♦ (1) 5VDC POWER SUPPLY WITH POWER CORD

\* EMD2002SE-T IS EOL. IT IS REPLACED BY EMD2002PE-T-R2.

# CHAPTER 1: SPECIFICATIONS

## SPECIFICATIONS FOR EMERALD SE TRANSMITTER AND RECEIVER, DUAL-HEAD (EMD2002SE-T AND EMD2002SE-R)

APPROVALS	
UNIT	Directive 2014/30/EU, CE, FCC, UKCA, 2011/65/EU, 2015/863/EU, Reach, TSCA, CB
POWER SUPPLY	Directive 2014/35/EU, EN 62368-1:2014, UL, cUL, GS, PSE, BSMI, RCM, BIS
PHYSICAL	
LED INTERFACE	(1) Power LED/button; NOTE: Unit automatically powers on when plugged in; must be powered off at the power source. (1) RJ-45 Speed LED (green, located on top left of RJ-45 connector): Blinks three times when the network connection is 1000 Mbps, Blinks two times when network connection is 100 Mbps, Blinks once when the network connection is 10 Mbps, Not blinking: No link to network; (1) Activity LED (green, located on top right of RJ-45 connector): Solid green: Link up, Blinking: Activity on the link, OFF: No link
MAXIMUM DISTANCE FROM CPU TO TRANSMITTER	5 m (16.4 ft.), DVI-D and USB limitations
MAXIMUM DISTANCE BETWEEN TRANSMITTER AND RECEIVER	328 ft. (100 m), use a network switch to get farther distances
OPERATING SYSTEM SUPPORT	Microsoft Windows® 10/11, Server OS, Linux®, and Mac OS
CONNECTORS	EMD2002SE-T: (2) DVI inputs, (1) USB Type B female, (1) RJ-45 network (10/100/1000BASE-T), (2) 3.5-mm audio, (1) 2.5-mm barrel for power; EMD2002SE-R: (2) DVI outputs, (4) USB Type A female, (1) RJ-45 network (10/100/1000BASE-T), (2) 3.5-mm audio for SPK and MIC, (1) 2.5-mm barrel for power
DIMENSIONS	EMD2002SE-T: 1.43" H x 6.2" W x 4.2" D (36 x 157 x 107 mm); EMD2002SE-R: 1.15" H x 6.2" W x 4.2" D (29 x 157 x 107 mm)
WEIGHT	EMD2002SE-T: 1.44 lbs (652 g); EMD2002SE-R: 1.32 lbs (600 g)
OPERATION	
DEFAULT IP ADDRESS	EMD2002SE-T: 192.168.1.22; EMD2002SE-R: 192.168.1.21
ENCRYPTION	Secure Sockets Layer (SSL) over TCP/IP, 128-bit between transmitter and receiver, user set between receiver and virtual machine
DEFAULT USERNAME	admin
DEFAULT PASSWORD	The password is blank by default.
DDC SUPPORT	Built-in/clone of remote
POWER	
POWER SOURCE	External in-line power supply
INPUT VOLTAGE	100–240 VAC, 50/60 Hz
INPUT CURRENT	0.9 Amps maximum
POWER CONSUMPTION	Unit: 6.5 W with keyboard and mouse attached; Power supply: 20 W to support USB-based powered devices
HEAT DISSIPATION	68.2 BTW/hr maximum
OUTPUT CONNECTOR	2.5-mm barrel (5 VDC, 4 Amp output)
INPUT CONNECTOR	IEC-320, C8
POWER SUPPLY CORD LENGTH	6 ft. (1.8 m)
ENVIRONMENTAL	
OPERATING TEMPERATURE	32 to 104° F (0 to 40° C)
STORAGE TEMPERATURE	-4 to +140° F (-20 to 60° C)
OPERATING HUMIDITY	5 to 95%, noncondensing



# CHAPTER 1: SPECIFICATIONS

## EMERALD PE SINGLE-HEAD TRANSMITTER (EMD2000PE-T-R2)

EMD2000PE-T-R2 FRONT VIEW



EMD2000PE-T-R2 BACK VIEW



### WHAT'S INCLUDED WITH THE TRANSMITTER (EMD2000PE-T-R2)

- (1) EMERALD PE TRANSMITTER, SINGLE-HEAD
- (1) 12VDC POWER SUPPLY WITH POWER CORD
- (1) DVI CABLE
- (1) USB 2.0 TYPE B CABLE

# CHAPTER 1: SPECIFICATIONS

## SPECIFICATIONS FOR EMERALD PE SINGLE-HEAD TRANSMITTER (EMD2000PE-T-R2)

APPROVALS	
UNIT	Directive 2014/30/EU, CE, FCC, ICES, UKCA, 2011/65/EU, 2015/863/EU, Reach, TSCA
POWER SUPPLY	Directive 2014/35/EU, EN 62368-1:2014, UL, cUL, GS, PSE, BSMI, RCM, BIS, CB
PHYSICAL	
LED INTERFACE	(1) Power LED; (1) Network LED; (1) Video 1 Status LED; (1) RJ-45 Speed LED (green, located on top left of RJ-45 connector): Blinks three times when the network connection is 1000 Mbps, Blinks two times when network connection is 100 Mbps, Blinks once when the network connection is 10 Mbps, Not blinking: No link to network; (1) Activity LED (green, located on top right of RJ-45 connector): Solid green: Link up, Blinking: Activity on the link, OFF: No link
MAXIMUM DISTANCE FROM CPU TO TRANSMITTER	5 m (16.4 ft.), DVI-D and USB limitations
MAXIMUM DISTANCE BETWEEN TRANSMITTER AND RECEIVER	328 ft. (100 m), use a network switch to get farther distances
OPERATING SYSTEM SUPPORT	Microsoft Windows® 10/11, Server OS, Linux®, and Mac OS
CONNECTORS	(1) DVI input, (1) USB Type B female, (1) RJ-45 network, (1) SFP network, (1) 3.5-mm audio, (1) 3-pin locking connector for power, (1) Micro USB connector;
DIMENSIONS	1.34" H x 7.64" W x 5.83" D (34 x 194 x 148 mm)
WEIGHT	1.03 lb. (468 g)
OPERATION	
DEFAULT IP ADDRESS	192.168.1.22
ENCRYPTION	Secure Sockets Layer (SSL) over TCP/IP, 128-bit between transmitter and receiver, user set between receiver and virtual machine
DDC SUPPORT	Built-in/clone of remote
POWER	
POWER SOURCE	External in-line power supply
INPUT VOLTAGE	100–240 VAC, 50/60 Hz
INPUT CURRENT	1 Amp maximum
POWER CONSUMPTION	Unit: 7.5 W with keyboard and mouse attached; Power supply: 36 W to support USB-based powered devices
HEAT DISSIPATION	122.76 BTW/hr maximum
OUTPUT CONNECTOR	3-pin locking connector (12 VDC, 3 Amp output)
INPUT CONNECTOR	IEC-320, C14
POWER SUPPLY CORD LENGTH	6 ft. (1.8 m)
ENVIRONMENTAL	
OPERATING TEMPERATURE	32 to 104° F (0 to 40° C)
STORAGE TEMPERATURE	-4 to +140° F (-20 to 60° C)
OPERATING HUMIDITY	5 to 95%, noncondensing



# CHAPTER 1: SPECIFICATIONS

## EMERALD PE DUAL-HEAD TRANSMITTER (EMD2002PE-T-R2)

EMD2002PE-T-R2 FRONT VIEW



EMD2002PE-T-R2 BACK VIEW



### WHAT'S INCLUDED WITH THE TRANSMITTER (EMD2002PE-T-R2)

- (1) EMERALD PE TRANSMITTER, DUAL-HEAD
- (1) 12VDC POWER SUPPLY WITH POWER CORD
- (2) DVI CABLES
- (1) USB 2.0 TYPE B CABLE

# CHAPTER 1: SPECIFICATIONS

## SPECIFICATIONS FOR EMERALD PE DUAL-HEAD TRANSMITTER (EMD2002PE-T-R2)

APPROVALS	
UNIT	Directive 2014/30/EU, CE, FCC, ICES, UKCA, 2011/65/EU, 2015/863/EU, Reach, TSCA
POWER SUPPLY	Directive 2014/35/EU, EN 62368-1:2014, UL, cUL, GS, PSE, BSMI, RCM, BIS, CB
PHYSICAL	
LED INTERFACE	(1) Power LED; (1) Network LED; (1) Video 1 Status LED; (1) Video 2 Status LED; (1) RJ-45 Speed LED (green, located on top left of RJ-45 connector): Blinks three times when the network connection is 1000 Mbps, Blinks two times when network connection is 100 Mbps, Blinks once when the network connection is 10 Mbps, Not blinking: No link to network; (1) Activity LED (green, located on top right of RJ-45 connector): Solid green: Link up, Blinking: Activity on the link, OFF: No link
MAXIMUM DISTANCE FROM CPU TO TRANSMITTER	5 m (16.4 ft.), DVI-D and USB limitations
MAXIMUM DISTANCE BETWEEN TRANSMITTER AND RECEIVER	328 ft. (100 m), use a network switch to get farther distances
OPERATING SYSTEM SUPPORT	Microsoft Windows® 10/11, Server OS, Linux®, and Mac OS
CONNECTORS	(2) DVI input, (1) USB Type B female, (1) RJ-45 network, (1) SFP network, (1) 3.5-mm audio, (1) 3-pin locking connector for power, (1) Micro USB connector
DIMENSIONS	1.32" H x 7.62" W x 5.79" D (34 x 194 x 147 mm)
WEIGHT	1.04 lb. (474 g)
OPERATION	
DEFAULT IP ADDRESS	192.168.1.22
ENCRYPTION	Secure Sockets Layer (SSL) over TCP/IP, 128-bit between transmitter and receiver, user set between receiver and virtual machine
DDC SUPPORT	Built-in/clone of remote
POWER	
POWER SOURCE	External in-line power supply
INPUT VOLTAGE	100–240 VAC, 50/60 Hz
INPUT CURRENT	0.9 Amps maximum
POWER CONSUMPTION	Unit: 7.5 W with keyboard and mouse attached; Power supply: 36 W to support USB-based powered devices
HEAT DISSIPATION	122.76 BTW/hr maximum
OUTPUT CONNECTOR	3-pin locking connector (12 VDC, 3 Amp output)
INPUT CONNECTOR	IEC-320, C14
POWER SUPPLY CORD LENGTH	6 ft. (1.8 m)
ENVIRONMENTAL	
OPERATING TEMPERATURE	32 to 104° F (0 to 40° C)
STORAGE TEMPERATURE	-4 to +140° F (-20 to 60° C)
OPERATING HUMIDITY	5 to 95%, noncondensing



# CHAPTER 1: SPECIFICATIONS

EMERALD SE SINGLE-HEAD DISPLAYPORT TRANSMITTER (EMD2000SE-DP-T) AND RECEIVER (EMD2000SE-DP-R)

TRANSMITTER FRONT VIEW



RECEIVER FRONT VIEW



TRANSMITTER BACK VIEW



RECEIVER BACK VIEW



## WHAT'S INCLUDED WITH THE TRANSMITTER (EMD2000SE-DP-T)

- (1) EMERALD SE DP TRANSMITTER, SINGLE-HEAD
- (1) 5VDC POWER SUPPLY WITH POWER CORD

## WHAT'S INCLUDED WITH THE RECEIVER (EMD2000SE-DP-R)

- (1) EMERALD SE DP RECEIVER, SINGLE-HEAD
- (1) 5VDC POWER SUPPLY WITH POWER CORD

# CHAPTER 1: SPECIFICATIONS

## SPECIFICATIONS FOR EMERALD SE DISPLAYPORT TRANSMITTER, SINGLE-HEAD (EMD2000SE-DP-T) AND RECEIVER (EMD2000SE-DP-R)

APPROVALS	
UNIT	Directive 2014/30/EU, CE, FCC, UKCA, 2011/65/EU, 2015/863/EU, Reach, TSCA
POWER SUPPLY	Directive 2014/35/EU, EN 62368-1:2014, UL, cUL, GS, PSE, BSMI, RCM, BIS
PHYSICAL	
LED INTERFACE	(1) Power LED; NOTE: Unit automatically powers on when plugged in; must be powered off at the power source. (1) RJ-45 Speed LED (green, located on top left of RJ-45 connector): Blinks three times when the network connection is 1000 Mbps, Blinks two times when network connection is 100 Mbps, Blinks once when the network connection is 10 Mbps, Not blinking: No link to network; (1) Activity LED (green, located on top right of RJ-45 connector): Solid green: Link up, Blinking: Activity on the link, OFF: No link
MAXIMUM DISTANCE FROM CPU TO TRANSMITTER	5 m (16.4 feet), DisplayPort™ and USB limitations
MAXIMUM DISTANCE BETWEEN TRANSMITTER AND RECEIVER	328 ft. (100 m), use a network switch to get farther distances
OPERATING SYSTEM SUPPORT	Microsoft Windows® 10/11, Server OS, Linux®, and Mac OS
CONNECTORS	EMD2000SE-DP-T: (1) DisplayPort input, (1) USB Type B, (1) RJ-45 network, (1) 3.5-mm audio, (1) 2.5-mm barrel connector for power, (1) RJ-45 Serial Console Connector; EMD2000SE-DP-R: (1) DisplayPort input, (4) USB Type A, (1) RJ-45 network, (1) 3.5-mm audio, (1) 2.5-mm barrel connector for power, (1) RJ-45 Serial Console Connector
DIMENSIONS	1.34" H x 5.39" W x 6.07" D (34 x 137 x 154 mm)
WEIGHT	0.73 lb. (335 g)
OPERATION	
DEFAULT IP ADDRESS	EMD2000SE-DP-T: 192.168.1.22; EMD2000SE-DP-R: 192.168.1.21
ENCRYPTION	Secure Sockets Layer (SSL) over TCP/IP, 128-bit between transmitter and receiver, user set between receiver and virtual machines
DDC SUPPORT	Built-in/clone of remote
POWER	
POWER SOURCE	External in-line power supply
INPUT VOLTAGE	100–240 VAC, 50/60 Hz
INPUT CURRENT	0.9 Amps maximum
POWER CONSUMPTION	Unit: 6.5 W with keyboard and mouse attached; Power supply: 20 W to support USB-based powered devices
HEAT DISSIPATION	68.2 BTU/hr maximum
OUTPUT CONNECTOR	2.5-mm barrel (5 VDC, 4 Amp output)
INPUT CONNECTOR	IEC-320, C8
POWER SUPPLY CORD LENGTH	6 ft. (1.8 m)
ENVIRONMENTAL	
OPERATING TEMPERATURE	32 to 104° F (0 to 40° C)
STORAGE TEMPERATURE	-4 to +140° F (-20 to 60° C)
OPERATING HUMIDITY	5 to 95%, noncondensing



# CHAPTER 1: SPECIFICATIONS

## EMERALD SE DUAL-HEAD DISPLAYPORT TRANSMITTER (EMD2002SE-DP-T) AND RECEIVER (EMD2002SE-DP-R)

TRANSMITTER FRONT VIEW



RECEIVER FRONT VIEW



TRANSMITTER BACK VIEW



RECEIVER BACK VIEW



### WHAT'S INCLUDED WITH THE TRANSMITTER (EMD2002SE-DP-T)

- (1) EMERALD SE DP TRANSMITTER, DUAL-HEAD
- (1) 12VDC POWER SUPPLY WITH POWER CORD

### WHAT'S INCLUDED WITH THE RECEIVER (EMD2002SE-DP-R)

- (1) EMERALD SE DP RECEIVER, DUAL-HEAD
- (1) 12VDC POWER SUPPLY WITH POWER CORD

# CHAPTER 1: SPECIFICATIONS

## SPECIFICATIONS FOR EMERALD SE DISPLAYPORT TRANSMITTER, DUAL-HEAD (EMD2002SE-DP-T) AND RECEIVER (EMD2002SE-DP-R)

APPROVALS	
UNIT	Directive 2014/30/EU, CE, FCC, UKCA, 2011/65/EU, 2015/863/EU, Reach, TSCA
POWER SUPPLY	Directive 2014/35/EU, EN 62368-1:2014, UL, cUL, GS, PSE, BSMI, RCM, BIS, CB
PHYSICAL	
LED INTERFACE	<p>(1) Power LED; NOTE: Unit automatically powers on when plugged in; must be powered off at the power source.</p> <p>(1) RJ-45 Speed LED (green, located on top left of RJ-45 connector):            Blinks three times when the network connection is 1000 Mbps,            Blinks two times when network connection is 100 Mbps,            Blinks once when the network connection is 10 Mbps,            Not blinking: No link to network;</p> <p>(1) Activity LED (green, located on top right of RJ-45 connector):            Solid green: Link up,            Blinking: Activity on the link,            OFF: No link</p>
MAXIMUM DISTANCE FROM CPU TO TRANSMITTER	5 m (16.4 ft.), DisplayPort™ and USB limitations
MAXIMUM DISTANCE BETWEEN TRANSMITTER AND RECEIVER	328 ft. (100 m), use a network switch to get farther distances
OPERATING SYSTEM SUPPORT	Microsoft Windows® 10/11, Server OS, Linux®, and Mac OS
CONNECTORS	<p>EMD2002SE-DP-T: (2) DisplayPort female, (1) USB Type B female, (1) 3.5-mm audio, (1) RJ-45 Interconnect, 1Gbps, (1) USB Type B micro (Console), (1) 3-pin locking connector for power (12VDC);</p> <p>EMD2002SE-DP-R: (2) DisplayPort female, (4) USB Type A female, (1) 3.5-mm audio, (1) RJ-45 Interconnect, 1Gbps, (1) USB Type B micro (Console), (1) 2.5-mm barrel for power (5VDC)</p>
DIMENSIONS	<p>EMD2002SE-DP-T: 1.34" H x 5.39" W x 6.07" D (34 x 137 x 154 mm);</p> <p>EMD2002SE-DP-R: 1.3" H x 7.62" W x 5.81" D (33.11 x 193.6 x 147.8mm)</p>
WEIGHT	<p>EMD2002SE-DP-T: 0.77 lbs (350 g)</p> <p>EMD2002SE-DP-R: 0.85 lbs (385 g)</p>
OPERATION	
DEFAULT IP ADDRESS	<p>EMD2002SE-DP-T: 192.168.1.22;</p> <p>EMD2002SE-DP-R: 192.168.1.21</p>
ENCRYPTION	Secure Sockets Layer (SSL) over TCP/IP, 128-bit between transmitter and receiver, user set between receiver and virtual machine
DDC SUPPORT	Built-in/clone of remote
POWER	
POWER SOURCE	External in-line power supply
INPUT VOLTAGE	100–240 VAC, 50/60 Hz
INPUT CURRENT	1 Amp maximum
POWER CONSUMPTION	<p>Unit: 9 W with keyboard and mouse attached;</p> <p>Power supply: 36 W to support USB-based powered devices</p>
HEAT DISSIPATION	<p>EMD2002SE-DP-T: 122.76 BTU/h maximum;</p> <p>EMD2002SE-DP-R: 68.2 BTU/h maximum</p>
OUTPUT CONNECTOR	<p>EMD2002SE-DP-T: 3-pin locking connector (12 VDC, 3 Amp output)</p> <p>EMD2002SE-DP-R: 2.5mm barrel (5 VDC, 4 Amp output)</p>
INPUT CONNECTOR	IEC-320, C14
POWER SUPPLY CORD LENGTH	6 ft. (1.8 m)
ENVIRONMENTAL	
OPERATING TEMPERATURE	32 to 104° F (0 to 40° C)
STORAGE TEMPERATURE	-4 to +140° F (-20 to 60° C)
OPERATING HUMIDITY	5 to 95%, noncondensing



# CHAPTER 1: SPECIFICATIONS

## 4K SINGLE-HEAD TRANSMITTER AND RECEIVER (EMD4000T AND EMD4000R)

FRONT VIEW



EMD4000T

FRONT VIEW

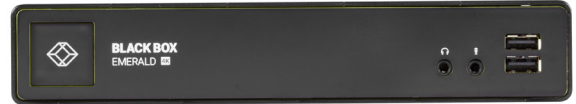

EMD4000R

BACK VIEW



EMD4000T

BACK VIEW



EMD4000R

### WHAT'S INCLUDED WITH THE TRANSMITTER

- (1) TRANSMITTER
- (1) 12VDC POWER SUPPLY WITH POWER CORD
- (1) DISPLAYPORT M/M CABLE
- (1) USB TYPE A TO B CABLE

### WHAT'S INCLUDED WITH THE RECEIVER

- (1) RECEIVER
- (1) 12VDC POWER SUPPLY WITH POWER CORD

NOTE: SFP+ sold separately.

# CHAPTER 1: SPECIFICATIONS

## 4K SINGLE-HEAD TRANSMITTER AND RECEIVER (EMD4000T AND EMD4000R)

4K SINGLE-HEAD EXTENDER (EMD4000R AND EMD4000T)	
<b>APPROVALS</b>	Unit: Directive 2014/30/EU, CE, FCC, ICES, UKCA, 2011/65/EU, 2015/863/EU, Reach, TSCA, CB Power Supply: Directive 2014/35/EU, EN 62368-1:2014, UL, cUL, GS, PSE, BSMI, CB, RCM, BIS
<b>CONNECTORS</b>	Transmitter: (1) DisplayPort™, (1) Power, (1) DB9 serial, (1) USB Type B, (1) RJ-45, (2) SFP+ cages (10GBASE-X/1000BASE-X), (2) 3.5-mm audio; Receiver: (1) DisplayPort, (1) Power, (1) DB9 serial, (4) USB Type A, (1) RJ-45, (2) SFP+ cages (10GBASE-X/1000BASE-X), (2) 3.5-mm audio
<b>DISTANCE</b>	Distance between Transmitter and Receiver: Unlimited using Ethernet switching to repeat.  Links distance only limited by Ethernet rules and cable/module performance: CATx: 328ft. (100m), dependent on module and cable used; Fiber: 984.2 ft. to 6.2 mi. (300 m to 10 km), based on SFP and cable used.
<b>INDICATORS</b>	(1) single bi-color LED (red/green)
<b>MAXIMUM RESOLUTION</b>	4096 x 2160 @ 60 Hz (High refresh rates at lower resolutions also possible)
<b>MATERIAL</b>	Aluminum outer case with plastic bezel
<b>OPERATING SYSTEMS SUPPORTED</b>	Microsoft Windows® 10/11, Server OS, Linux®, Mac OS
<b>OPERATION</b>	Default IP Address for Transmitter:192.168.1.22; Default IP Address for Receiver: 192.168.1.21; Default Username: admin; Default Password: Blank password by default, just press the Enter key; EDID Support: Internal EDID table in transmitter (can be updated from a receiver or manager or real monitor EDID can be used if cloned); Encryption: Secure Sockets Layer (SSL) over TCP/IP up to 128-bit for transmitter to receiver connections. For VM targets, encryption specification is dependent upon configuration.
<b>ENVIRONMENTAL</b>	Operating Temperature: 32 to 104° F (0 to 40° C); Storage Temperature: -4°F to 140°F (-20° C to 60° C); Operating Humidity: 5–95%
<b>POWER</b>	External desktop-style adapter, 100–240 VAC input, 12 VDC, 3 A connection to unit
<b>POWER CONSUMPTION</b>	36 Watts maximum
<b>HEAT DISSIPATION</b>	122.8 BTU/h
<b>DIMENSIONS</b>	Each unit: 1.5" H x 8.5" W x 7.4" D (38 x 216 x 188 mm)
<b>WEIGHT</b>	EMD4000T: 2.49 lbs (1130 g); EMD4000R: 2.48 lbs (1129 g)



# CHAPTER 1: SPECIFICATIONS

MTBF	
EMD200DV-T	1,000,000 Calculated Hours at 25°C , by Telcordia SR-332
EMD200DP-T	930,000 Calculated Hours at 25°C , by Telcordia SR-33
EMD2000SE-T	800,000 Calculated Hours at 25°C , by Telcordia SR-332
EMD2000SE-T-R2	675,000 Calculated Hours at 25°C , by Telcordia SR-332
EMD2000SE-R	800,000 Calculated Hours at 25°C , by Telcordia SR-332
EMD2000SE-DP-T	300,000 hours (estimated)
EMD2000SE-DP-R	>700k
EMD2000PE-T	340,000 Calculated Hours at 25°C , by Telcordia SR-332
EMD2000PE-T-R2	>700k
EMD2000PE-R	320,000 Calculated Hours at 25°C , by Telcordia SR-332
EMD2000PE-R-P	320,000 Calculated Hours at 25°C , by Telcordia SR-332
EMD2000PE-DP-T	300,000 hours (estimated)
EMD2000PE-DP-R	>700k
EMD2002SE-T	950,000 Calculated Hours at 25°C , by Telcordia SR-332
EMD2002SE-R	900,000 Calculated Hours at 25°C , by Telcordia SR-332
EMD2002SE-DP-T	300,000 hours (estimated)
EMD2002SE-DP-R	>700k
EMD2002PE-T	320,000 Calculated Hours at 25°C , by Telcordia SR-332
EMD2002PE-T-R2	>700k
EMD2002PE-R	300,000 hours (estimated)
EMD2002PE-R-P	320,000 Calculated Hours at 25°C , by Telcordia SR-332
EMD2002PE-DP-T	300,000 hours (estimated)
EMD2002PE-DP-R	>700k
EMD4000T	810,000 Calculated Hours at 25°C , by Telcordia SR-332
EMD4000R	860,000 Calculated Hours at 25°C , by Telcordia SR-332

NOTE: The values above are either based upon actual calculations or estimations. This table will be updated over time when calculations are performed. The calculated values are designated with a method while the estimates are more general and have no method. If you require calculated estimates, contact Black Box technical support.



# CHAPTER 1: SPECIFICATIONS

## 1.2 LICENSING

There are 2 options for managing Emerald® transmitters and receivers:

- ◆ Option 1 (for small unmanaged matrices that have less than 32 connections and users): Using built-in receiver manager
- ◆ Option 2 (for large managed matrices with more than 32 connections and users, requires RemoteApp, and additional features such as LDAP integration and SYSLOG): Using Boxilla® BXAMGR or BXAMGR-R2

**NOTE:** For managed installations with more than 32 users, you will need to use Boxilla KVM Manager. The basic Boxilla license (BXAMGR-R2) supports 25 users, 25 devices, and 25 connections.

Other available licenses for Boxilla are listed below:

- ◆ Boxilla Manager with 25 Endpoint Licenses (BXAMGR-R2)
- ◆ Boxilla Manager with 75 Endpoint Licenses (BXAMGR-R2-75)
- ◆ Boxilla Manager with 125 Endpoint Licenses (BXAMGR-R2-125)
- ◆ Boxilla Manager with 225 Endpoint Licenses (BXAMGR-R2-225)
- ◆ Boxilla Manager with 325 Endpoint Licenses (BXAMGR-R2-325)
- ◆ Boxilla Manager with Unlimited Endpoint Licenses (BXAMGR-R2-ULT)

Available upgrade licenses for Boxilla are listed below:

- ◆ Add 25 Users, Devices or Connections (BXAMGR-LIC-25)
- ◆ Add 100 Users, Devices or Connections (BXAMGR-LIC-100)
- ◆ Add 200 Users, Devices or Connections (BXAMGR-LIC-200)
- ◆ Add 300 Users, Devices or Connections (BXAMGR-LIC-300)
- ◆ Add Unlimited Users, Devices or Connections (BXAMGR-LIC-ULT)

License bundles are recommended when the system contains two Boxilla managers in a primary/backup configuration. The bundle will provide the same license to the primary and backup so that they match.

Licenses for active and standby Boxilla are listed below:

- ◆ 25 Devices (BXAMGR-LICBAK25)
- ◆ 100 Devices (BXAMGR-LICBAK100)
- ◆ 200 Devices (BXAMGR-LICBAK200)
- ◆ 300 Devices (BXAMGR-LICBAK300)



# CHAPTER 2: OVERVIEW

The Emerald® system provides users with a seamless desktop experience anywhere on a TCP/IP network, while allowing the actual hardware to be securely housed in a corporate data center or in the cloud. Emerald enables the same high-fidelity experience of a desktop PC even for media-rich applications, such as watching videos, photo editing with Photoshop, or 3D design with AutoCAD. The remote desktops may be hosted on a physical PC/workstation, or they may be a virtual desktop hosted on a private server or in the cloud.

The Emerald system provides its users with receivers that communicate with target computer nodes (whether physical PC or virtual desktop) over a standard TCP/IP network. Physical PCs/workstations/servers have an Emerald SE or PE transmitter unit or Emerald ZeroU DVI or DisplayPort™ transmitter unit physically connected to provide communication over the TCP/IP network. The performance of Emerald allows them to be deployed on standard corporate networks and even across Wide-Area-Networks (WANs).

Desktop users can access remote keyboard, mouse, video, audio, USB mass storage devices, headsets and other USB devices from the receiver unit to the remote PC/workstations or virtual desktop via the Emerald system.

**NOTE:** Not all USB 2.0 devices are supported depending on how they negotiate/communicate with the host. If you find your USB 2.0 device isn't working properly, we recommend upgrading the firmware to v6.10 or later which adds better control of USB 2.0 devices. Refer to the Emerald receiver USB Devices section for further information on how to view and properly assign USB 2.0 devices.

**NOTE:** References to the Emerald 2K system in this document refer to both receivers (EMD2000PE-R, EMD2000SE-R, EMD2002PE-R, EMD2000PE-R-P, EMD2002PE-R-P, EMD2002SE-R, EMD2000SE-DP-R, EMD2002SE-DP-R, EMD2000PE-DP-R, and EMD2002PE-DP-R) and transmitters (EMD200DV-T, EMD2000PE-DP-T, EMD2000PE-T, EMD2000PE-T-P, EMD2000SE-DP-T, EMD2000SE-T, EMD2000SE-T-R2, EMD2002PE-DP-T, EMD2002PE-T, EMD2002PE-T-P, EMD2002SE-DP-T, EMD2002SE-T, EMD2000PE-T-R2, and EMD2002PE-T-R2). The Emerald 2K ZeroU DVI or DisplayPort transmitter (EMD200DP-T, EMD200DV-T) can be used in place of the SE or PE transmitter where rack space is limited, but these devices cannot support USB redirection. The Emerald 4K system in this document refers to the EMD4000T (transmitter) and EMD4000R (receiver).

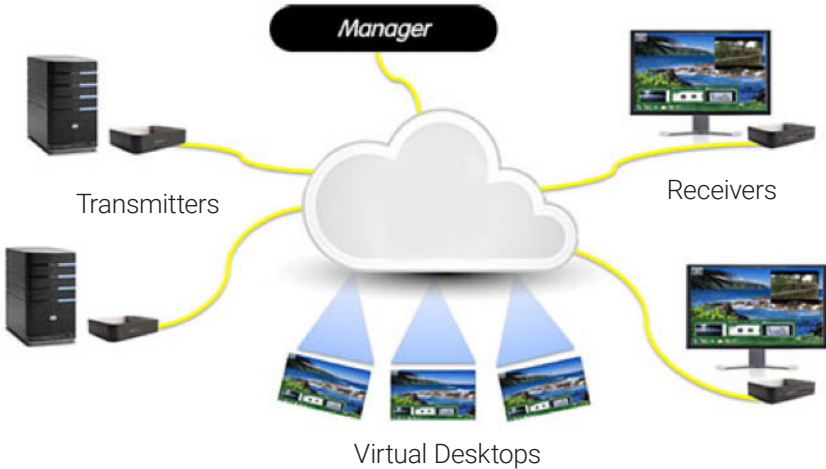

FIGURE 2-1. EMERALD EXAMPLE—INCLUDING PHYSICAL AND VIRTUAL DESKTOPS

## CHAPTER 2: OVERVIEW

### 2.1 EMERALD SYSTEM FEATURES

Emerald® leverages state-of-the-art technologies in compression, networking, and latency management. Some of the key features of Emerald are:

- ♦ **Pixel-Perfect Video Quality:** The Emerald system uses a compound compression algorithm to provide a lossless video experience at a low-network bandwidth. None of the bandwidth variability and noise effects of analog extension schemes exist.
- ♦ **Optimized Codec for Unicast streams:** Emerald 2K devices use an “Optimized” codec for Unicast streams, even for shared mode, to allow scaling of the number of users that can share a transmitter. Analog audio can also now be shared in a shared mode connection. Emerald 4K devices use Unicast for private Lossless codec streams and also for both private and shared Optimized codec connections; they use Multicast for shared Lossless connections.
- ♦ **Seamless integration of Physical and Virtual Desktops:** The Emerald system connects to physical PCs, servers, and video sources as well as virtual desktops hosted on servers or in the cloud. This allows seamless connection to physical resources and virtual resources from the same receiver unit. IT professionals use this capability to optimize their deployments and migrations to cloud services.
- ♦ **High Reliability and Highly Secure:** The Emerald system minimizes maintenance for administrators. The intuitive On-Screen Display (OSD) is simple to learn and understand. The individual units have no moving parts to minimize potential for hardware failures. All media streams transmitted between the Emerald devices are encrypted using 128-bit SSL. Password protection is also provided to control access to all administration functions.
- ♦ **Environmentally Optimized:** The Emerald system is optimized to minimize power requirements and eliminate noise. All receivers and transmitters consume less than 9 watts of power and are completely silent.
- ♦ **Easy Deployment:** The Emerald system is designed to be easily and quickly deployed. No new drivers or software need to be installed on target PCs or virtual desktops (unless RemoteApp and/or DESKVUE is being used and the transmitter HID setting is set for Absolute, which requires ABS Multiscreen drivers). The system uses standard networking protocols and cabling. Users and connections are defined using an intuitive OSD. Connections can be made by clicking on target. Multiple modes of operation, such as private connections, shared connections, auto-login, and auto-connect, enable various workflows and collaborations to be supported. Analog audio can now be shared in a shared mode connection.
- ♦ **The Emerald ZeroU DVI or DisplayPort™ transmitter features a small form factor to use zero rack space—you save money when rack space is expensive. This transmitter can be powered over USB or via an optional power supply.**
- ♦ **Compatible with the Emerald Deskvue receivers (EMD5004-R, EMD5104-R, and EMD5004PE-R)**



# CHAPTER 2: OVERVIEW

## 2.2 OVERVIEW OF EMERALD DEVICES

The Emerald family is composed of 11 receivers, 16 transmitters, and a Boxilla Manager.

TABLE 2-1. EMERALD MODELS

RECEIVER	NUMBER OF VIDEO HEADS	USB PORTS	SERIAL	AUDIO	POE	DVI CPU CABLE	DISPLAYPORT CPU CABLE	USB CPU CABLE
EMD2000SE-R	(1) DVI	(4) USB 2.0 Type A	Yes	Yes	No	Not applicable	Not applicable	Not applicable
EMD2002SE-R	(2) DVI	(4) USB 2.0 Type A	No	Yes	No	Not applicable	Not applicable	Not applicable
EMD2000PE-R	(1) DVI	(4) USB 2.0 Type A	No	Yes	No	Not applicable	Not applicable	Not applicable
EMD2002PE-R	(2) DVI	(4) USB 2.0 Type A	No	Yes	No	Not applicable	Not applicable	Not applicable
EMD2000PE-R-P	(1) DVI	(4) USB 2.0 Type A	No	Yes	Yes	Not applicable	Not applicable	Not applicable
EMD2002PE-R-P	(2) DVI	(4) USB 2.0 Type A	No	Yes	Yes	Not applicable	Not applicable	Not applicable
EMD2000SE-DP-R	(1) DisplayPort™	(4) USB 2.0 Type A	No	Yes	No	Not applicable	Not applicable	Not applicable
EMD2002SE-DP-R	(2) DisplayPort	(4) USB 2.0 Type A	No	Yes	No	Not applicable	Not applicable	Not applicable
EMD2000PE-DP-R	(1) DisplayPort	(4) USB 2.0 Type A	No	Yes	No	Not applicable	Not applicable	Not applicable
EMD2002PE-DP-R	(2) DisplayPort	(4) USB 2.0 Type A	No	Yes	No	Not applicable	Not applicable	Not applicable
EMD4000R	(1) DisplayPort	(4) USB 2.0 Type A	No	Yes	No	Not applicable	Not applicable	Not applicable
TRANSMITTER	NUMBER OF VIDEO HEADS	USB PORTS	SERIAL	AUDIO	POE	DVI CPU CABLE	DISPLAYPORT CPU CABLE	USB CPU CABLE
EMD2000SE-T	(1) DVI	(1) USB 2.0 Type B	Yes	Yes	No	Not included	Not applicable	Not included
EMD2002SE-T	(2) DVI	(1) USB 2.0 Type B	No	Yes	No	Not included	Not applicable	Not included
EMD2000SE-T-R2	(1) DVI	(1) USB 2.0 Type B	No	Yes	No	Not included	Not applicable	Not included
EMD2000PE-T	(1) DVI	(1) USB 2.0 Type B	No	Yes	No	(1) included	Not applicable	Not included
EMD2000PE-T-P	(1) DVI	(1) USB 2.0 Type B	No	Yes	Yes	(1) included	Not applicable	Not included
EMD2000PE-T-R2	(1) DVI	(1) USB 2.0 Type B	No	Yes	No	(1) included	Not applicable	Included
EMD2002PE-T-R2	(2) DVI	(1) USB 2.0 Type B	No	Yes	No	(2) included	Not applicable	Included
EMD2002PE-T	(2) DVI	(1) USB 2.0 Type B	No	Yes	No	(2) included	Not applicable	Not included
EMD2002PE-T-P	(2) DVI	(1) USB 2.0 Type B	No	Yes	Yes	(2) included	Not applicable	Not included
EMD200DV-T	(1) DVI	(1) USB HID, (1) USB HID for power only	No	Yes	No	Not included	Not applicable	Not included
EMD200DP-T	(1) DisplayPort	(1) USB HID Type A, (1) USB HID Type A for power only	No	Yes, Embedded	No	Not included	Not applicable	Not included
EMD2000PE-DP-T	(1) DisplayPort	(1) USB 2.0 Type B	No	Yes	No	Not applicable	Included	Included
EMD2000SE-DP-T	(1) DisplayPort	(1) USB 2.0 Type B	Yes	Yes	No	Not applicable	Not included	Not included
EMD2002PE-DP-T	(2) DisplayPort	(1) USB 2.0 Type B	No	Yes	No	Not applicable	Included	Included
EMD2002SE-DP-T	(2) DisplayPort	(1) USB 2.0 Type B	No	Yes	No	Not applicable	Not included	Not included
EMD4000T	(1) DisplayPort	(1) USB 2.0 Type B	No	Yes	No	Not applicable	Included	Included
MANAGER	NUMBER OF VIDEO HEADS	USB PORTS	SERIAL	AUDIO	POE	DVI CPU CABLE	DISPLAYPORT CPU CABLE	USB CPU CABLE
BXAMGR-R2	(1) VGA	(4) USB 2.0 Type A	Yes	Yes	No	Not applicable	Not applicable	Not applicable



## CHAPTER 2: OVERVIEW

NOTE: A serial port is not currently supported to pass RS-232 data between TX and RX. A USB serial converter must be used with USB redirection.

Some of the key capabilities and operation of Emerald® devices are described next. These capabilities are supported across all Emerald devices.

### 2.2.1 VIDEO

---

The Emerald system supports 24-bit color depth digital video up to a maximum resolution of 1920x1200 at 60 Hz for Emerald 2K devices (non EMD4000T, non EMD4000R), and up to 3840x2160 at 60Hz for the Emerald 4K devices (EMD4000T, EMD4000R) for any video head on both transmitter and receiver. One or two DVI-I or DisplayPort™ connectors are provided on the receiver or transmitter for video cable compatibility, but only digital video is supported. See “Appendix A - Emerald Video Resolutions Supported” for the list of resolutions Emerald currently supports. VGA or analog video can be supported by using the KVGA-DVID VGA to DVI-D converter, but it should only be used with single-head DVI transmitters because of the dithering options. If used with a dual-head transmitter, the video quality will not be as good as it is with the single-head model.

### 2.2.2 AUDIO

---

The Emerald system supports CD-quality stereo audio from the remote workstation (with the transmitter connected) or virtual desktop to peripheral speakers connected to the USB connector on the Emerald receiver. The Emerald transmitter uses its USB interface to capture audio from the remote workstation. This increases audio quality by eliminating analog audio noise issues and removing the need for a sound card in PC/workstation.

The Emerald receiver connects audio from a peripheral microphone connected via the USB connector on the receiver to the remote workstation or a virtual desktop. The Emerald transmitter uses USB to supply the microphone data to the remote workstation. Higher quality audio can be obtained using USB redirection for USB headsets or speakers.

The Emerald ZeroU DVI transmitter has just one audio connector (used to connect speakers). The Emerald ZeroU DisplayPort transmitter has embedded audio over the DisplayPort connector.

NOTE: Some models, such as the SE and PE DisplayPort units, do not have a 3.5-mm microphone connector and will require a USB microphone to be used.

### 2.2.3 SUPPORT FOR KEYBOARDS, MICE, AND USB DEVICES

---

Standard 104/105 keyed keyboards and both USB keyboards and mice are fully supported by the Emerald system. Composite mouse and keyboard devices are supported, along with other types of USB devices, such as flash/thumb Drives, CD and DVD-ROM drives, printers, pen tablets, touch-panels, and isochronous USB devices, such as headsets. Specialized keyboards that support LCD panels, macro keys, card readers, and internal USB hubs typically require the use of the USB Redirection channel.

Support for non-keyboard and mice devices is provided on an Emerald receiver using USB redirection. This capability can be enabled or disabled (and configured) by the Administrator. In an Emerald receiver, the first two devices that are not keyboard or mouse are assigned to the USB redirection channel automatically and passed to the remote computer when connected via a transmitter. When connecting to a non-transmitter target, such as a virtual desktop, up to eight USB devices can be redirected. The EMD200DV/EMD200DP series does not support USB redirection and only supports keyboard and mouse devices.

NOTE: A hub can be attached externally to an Emerald receiver, but a maximum of two devices can be assigned to USB redirection on connections to transmitters. Multiple keyboard and mice can additionally be supported, although all use the default drivers on the target PC.



## CHAPTER 2: OVERVIEW

### 2.2.4 IP ADDRESSING

---

The Emerald® devices are IP-addressable, giving you the flexibility to locate workstations anywhere within your enterprise and at any distance from your desktop users. The Emerald devices use standard network protocols to transfer data between the remote workstation/virtual desktop and the peripheral devices located at the user's desk. The Emerald 2K system can operate on a network connection of 100 Mbps or 1 Gbps, but it is highly recommended to use a 1 Gbps link for best performance and experience. The Emerald 4K system (EMD4000T, EMD4000R only) can operate at either 10 Gbps or 1 Gbps, depending upon the module used, but have the capability of allowing a 1 Gbps 2K receiver to establish a connection to it either way using the "Optimized scaled" configuration option for only the 4K transmitter. The receiver can be configured using a static or DHCP assigned IP address while the transmitter requires a static IP address only. It is strongly recommended to use static IP addresses for the receivers.

### 2.2.5 FIRMWARE UPGRADE

---

Upgrade your firmware using Boxilla® or by using a USB flash-drive in an Emerald receiver unit to ensure that your Emerald system is always running the most current version available. The Emerald devices—receiver and transmitter—are upgradable. There are cases where firmware upgrade / downgrade restrictions may apply (i.e. Emerald SE Receivers cannot be downgraded below 6.2 once upgraded to 6.2 or later). Contact technical support for more information.

## 2.3 APPLICATION EXAMPLES

The Emerald system is built to be flexible so that it can be deployed in many different types of applications, such as basic extension, switching applications (sometimes called matrix), cloud-based desktops, control rooms, digital signage, and kiosk applications, and other applications in banking, financial services, broadcast, network operations, industrial, government and enterprise computing sectors. Emerald provides the state-of-the art performance by:

- ♦ using digital sources for video and audio, hence removing analog noise issues or other potential environmental issues
- ♦ using advanced optimized compression to enable visually lossless video over standard low-bandwidth networks rather than a proprietary connection or dedicated gigabit networks of many systems

### 2.3.1 VIDEO, AUDIO, AND USB EXTENSION

---

Many applications require video, audio, or USB extension (or all three together), such as PC back-racking, board-room fit-out, remote monitoring, and digital signage.

The Emerald system is set up to connect the transmitter to the receiver straight out of the box on a point-to-point network. The transmitter and receiver can be attached to standard Ethernet IP networks to increase the distance between units – within a building, between buildings, or across a country. Only standard Ethernet/IP rules and the maximum latency the application can tolerate need to be considered. If video and/or audio extension only is being used, latency rarely is a consideration as the traffic is typically one-way. When USB-based peripheral devices are also required, a network latency of <50 ms is recommended to avoid user issues, such as poor mouse response. For some applications, such as graphic design network latency, <20 ms may be required to ensure user satisfaction. Latency normally is only an issue when extending across a WAN, because latency inside modern buildings or on dedicated networks is much less than 1 ms.

NOTE: Emerald is capable of operating on connections that have latency up to 100ms, although <20ms is recommended and anything above 100ms will have undesired results.



# CHAPTER 2: OVERVIEW

In Figure 2-2, a typical deployment is shown in a basic extender application. In this deployment, only one transmitter and receiver are used to allow remote access to a single workstation.

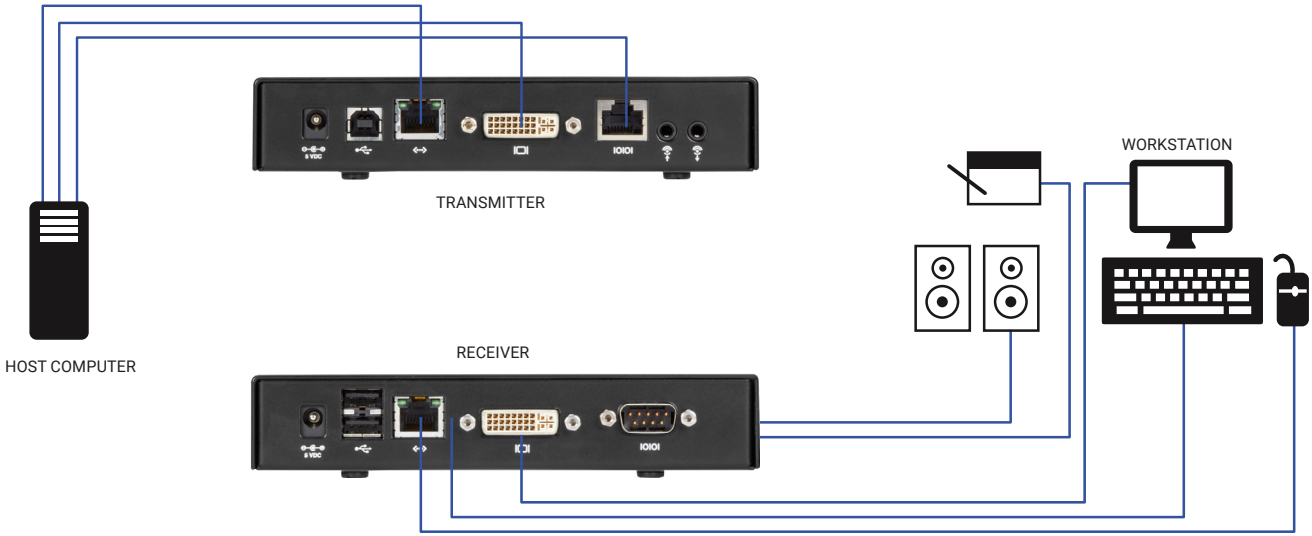

FIGURE 2-2. BASIC EXTENDER APPLICATION

## 2.3.2 VIDEO, AUDIO, AND USB SWITCHING

Numerous applications require being able to switch between different target PCs or virtual desktops. The user wants to be able to change the source of video, audio, or USB extension (or all three together).

Connections can be made to a target using Emerald’s intuitive OSD, API, Boxilla® Viewer (if using Boxilla), or Favorite Hot-keys. In Figure 2-3, a larger scale system is shown. This is referred to as a switching or matrix type of deployment. In this deployment, there are several receivers and transmitters and a manager, as well as virtual desktops.

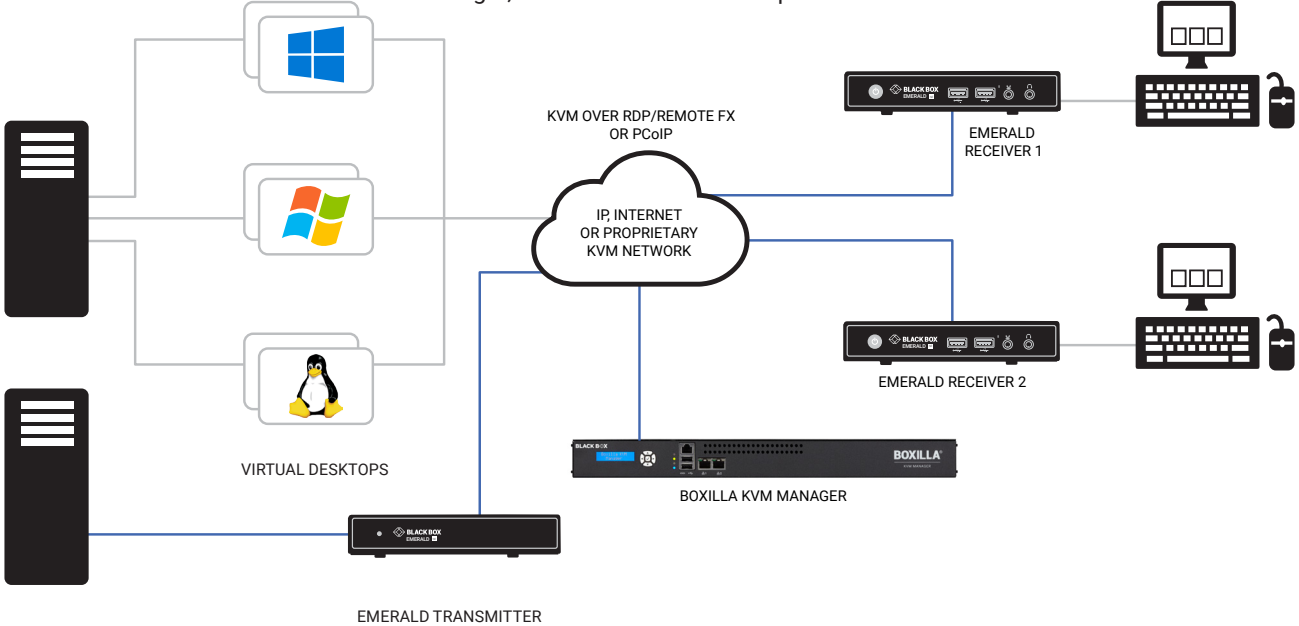

FIGURE 2-3. EMERALD SWITCHING EXAMPLE

# CHAPTER 3: CONFIGURATION

## 3.1 RECEIVER CONFIGURATION

An Emerald® receiver connects to a physical PC using an Emerald transmitter or a virtual desktop over a TCP/IP network and decrypts and decompresses the streams to provide video, audio, and USB connections to a user. The user is presented with typical PC connections—video out (typically DVI or DisplayPort™), USB (typically 4 ports of USB 2.0), line out, and microphone in (see the individual receiver's data sheet for specific ports provided).

The receiver is configured using an On-Screen Display (OSD) built into the receiver or using the Boxilla® Manager. The network settings and unit name are examples of receiver settings. The target connections are defined by their target name or IP address, log-in username/password, and TCP port number to be used. Users can be created and specific connections may be allocated to the different users.

A receiver user profile is protected by username and password to permit different users to access the same unit securely.

### Multiplatform support

Emerald is compatible with the following operating systems:

- ♦ Microsoft Windows® desktop operating systems, such as Windows 10 and Windows 11, and Microsoft Server operating systems, such as Server 2008, Server 2016, or Server 2020
- ♦ Linux®
- ♦ Mac OS®

The default keyboard drivers for these operating systems are supported by the Emerald system.

NOTE: For virtual desktops, typically Pro or Enterprise versions of the Windows operating system are required for VDI to support RemoteFX™. See [www.microsoft.com](http://www.microsoft.com) for Terminal Services (RDSH) or VDI (RDVH) requirements.

NOTE: Older operating systems and specialized operating systems may be supported even though they are not shown here. If your operating system does not appear in the above list, contact us.



## CHAPTER 3: CONFIGURATION

### 3.2 TRANSMITTER CONFIGURATION

An Emerald® transmitter converts the video, audio, and USB connections of a PC or workstation to a format that can be connected and controlled over a TCP/IP network. The transmitter connects to the DVI or DisplayPort™ and USB ports of a PC or workstation. The transmitter controls the connection to a remote receiver and manages the flow of information to it. It converts and compresses video and audio information for transmission over standard TCP/IP networks, along with USB peripheral communications. All data communication uses 128-bit encryption.

The transmitter is configured from an Emerald receiver or Boxilla® Manager. The network settings, unit name, and video quality are among the parameters that can be configured on a transmitter.

**NOTE:** For each EMD4000T transmitter, you need to configure a unique device IP (as with all other device types), and you will also need to configure a unique multicast IP address.

#### **Multiplatform support**

The transmitter is connected to the remote workstation via USB and DVI or DisplayPort connectors. This enables the Emerald receiver to interoperate seamlessly with Windows®, Linux®, and Macintosh® workstations/servers.



## CHAPTER 3: CONFIGURATION

### 3.3 BOXILLA MANAGER CONFIGURATION

In a basic installation, you can configure Emerald® via an Emerald receiver's built-in OSD display. For larger installations, a Boxilla® Manager (BXAMGR and BXAMGR-R2) can manage a network of Emerald receivers and transmitters. The BXAMGR can manage 25 transmitters/receivers by default with the included default license. The Boxilla manager is capable of supporting up to 4096 combined Emerald transmitters and receivers.

A Boxilla user profile is protected by username and password to permit different users to access the same unit securely. It maintains the central database that is distributed to all receivers in the domain of the Boxilla (for example, discovered and added to manager) – called the managed domain. This distribution ensures that there is no single point of failure in the Emerald system – each receiver has a copy of the database. This enables each receiver to continue operation – log users in, make connections as required – even if the Boxilla goes off-line.

Using the intuitive Boxilla web-based interface, one or more Administrators can manage potentially thousands of users who are interacting with an almost unlimited number of devices. Boxilla operates as a self-contained compact server unit that can be located anywhere within your network. Boxilla is supplied pre-loaded and is straightforward to deploy, requiring only a network connection and a power input to begin operation.

The current version of Boxilla provides management of Black Box's Emerald system. For more information on Boxilla, refer to the Boxilla user manual.



# CHAPTER 4: MODES OF OPERATION

The Emerald® system has various modes of operation: Auto-Login, Auto-Connect, Private Connection, Shared Connection, and Video Source Optimization modes.

## 4.1 AUTO-LOGIN

In Auto-Login Mode, turning on the Emerald receiver automatically causes a login as a pre-defined user. The user is presented with the permitted connections that have been predefined.

## 4.2 AUTO-CONNECT

In Auto-Connect Mode, when a user logs-in to the Emerald receiver, it causes an automatic connection to their pre-allocated workstation or virtual desktop. Auto-Login and Auto-Connect are defined independent of each other, but they can be used together to auto login/auto connect devices that are difficult to reach.

## 4.3 PRIVATE CONNECTION

In Private Connection Mode, when a user makes a connection to a target workstation/virtual desktop, this connection is only accessible by this user. All other users will receive a busy message if they attempt to connect to the same workstation/virtual machine. This is the default mode for connections.

## 4.4 SHARED CONNECTION

In Shared Connection Mode, multiple users can connect to the audio and video of the same target computer over the network. They arbitrate for control of the keyboard and mouse of that computer. Non-keyboard and mice devices are not supported on shared connections, such as USB 2.0 devices, due to the timing/OS limitations. Analog audio can now be shared in a shared mode connection.

These various modes can be mixed on a particular receiver and connection. For example, Auto-Login and Auto-Connect can be combined to enable an Emerald receiver to automatically connect to a specific target workstation/virtual desktop when power is applied without any user intervention that might be required for digital signage or kiosk type of deployments. When using the Emerald 4K appliances in shared mode, be sure to configure the 10 Gbps network switch to support IGMP Snooping for multicast network traffic.

## 4.5 VIDEO SOURCE OPTIMIZATION

**Off:** In this mode, the transmitter does not perform any additional video functions to manage the video input bandwidth. This mode assumes you are not using any analog-to-digital converters or a Temporal Dithering GPU. If you are using converters or have a GPU that does Temporal Dithering, this setting will not work very well as it will saturate the transmitter and cause severe latency.

**DVI Optimized:** This mode is designed to be used with GPUs that support Temporal Dithering. When the GPU updates every pixel on every frame to show a more vibrant video output, the transmitter in this mode can now ignore certain pixel updates to reduce the risk of GPU bandwidth saturation that can lead to severe latency.

### VGA

**A: VGA High Performance:** When using an analog-to-digital video converter, these devices can cause video noise to be injected on the signal. The transmitter will view this as a noisy source or a GPU that is using Temporal Dithering. This option is designed more for VGA to DVI/HDMI converters and will perform the function at a low capacity.

**B: VGA Optimized:** When using an analog-to-digital video converter, these devices can cause video noise to be injected on the signal. The transmitter will view this as a noisy source or a GPU that is using Temporal Dithering. This option is designed more for VGA to DVI/HDMI converters and will perform the function at a medium capacity.

**C: VGA Low Bandwidth:** When using an analog-to-digital video converter, these devices can cause video noise to be injected on the signal. The transmitter will view this as a noisy source or a GPU that is using Temporal Dithering. This option is designed more for VGA to DVI/HDMI converters and will perform the function at a high capacity, filtering the most pixels. This setting is considered to be the most aggressive mode.

NOTE: Only single-head transmitters support Video Source Optimization; dual-head and Emerald 4K devices do not support it.



## CHAPTER 5: INSTALLATION

### 5.1 EMERALD RECEIVER (EMD2000SE-R, EMD2002SE-R, EMD2000PE-R, EMD2000PE-R-P, EMD2002PE-R, EMD2002PE-R-P) CHECKLIST

Before installing your Emerald® SE or PE receiver, refer to the list below to ensure that you have all the items necessary for installation:

- ◆ Emerald SE or PE receiver
- ◆ External power supply for the receiver
- ◆ Power cord
- ◆ Emerald SE or PE Quick Installation Guide (QIG)

### 5.2 EMERALD TRANSMITTER (EMD2000SE-T, EMD2002SE-T, EMD2000PE-T, EMD2000-PE-T-P, EMD2002PE-T, EMD2002PE-T-P, EMD2000SE-T-R2, EMD2000PE-T-R2, EMD2002PE-T-R2) CHECKLIST

Before installing your Emerald SE or PE transmitter, refer to the list below to ensure that you have all the items necessary for installation:

- ◆ Emerald SE or PE transmitter
- ◆ External power supply for the transmitter
- ◆ Power cord
- ◆ Emerald SE or PE Quick Installation Guide (QIG)
- ◆ The SE transmitter does not include any video or USB CPU cables. The PE transmitter comes with all of the required CPU cables.

### 5.3 EMERALD SE OR PE TRANSMITTER KIT (EMD2000SE-T-K, EMD2002SE-T-K, EMD2000PE-K, AND EMD2002PE-K) CHECKLIST

Before installing your Emerald SE or PE transmitter, refer to the list below to ensure that you have all the items necessary for installation:

- ◆ Emerald SE or PE transmitter
- ◆ External power supply for the transmitter
- ◆ Power cord
- ◆ PE Kit only: DVI cable(s) (One DVI-D cable included for single-head, two DVI-D cables included for dual-head)
- ◆ PE Kit only: USB A to USB B device cable
- ◆ Emerald SE or PE Quick Installation Guide (QIG)

NOTE: The Emerald SE kits (EMD2000SE-T-K and EMD2002SE-T-K) do not contain any video or USB CPU cables. These cables must be purchased separately.



## CHAPTER 5: INSTALLATION

### 5.4 EMERALD ZEROU DVI OR DP TRANSMITTER (EMD200DV-T OR EMD200DP-T) CHECKLIST

- ◆ Emerald® ZeroU DVI transmitter (EMD200DV-T) or Emerald ZeroU DisplayPort™ transmitter (EMD200DP-T)

### 5.5 EMERALD DISPLAYPORT SE AND PE TRANSMITTERS (EMD2000PE-DP-T, EMD2000SE-DP-T, EMD2002PE-DP-T, EMD2002SE-DP-T) CHECKLIST

Before installing your Emerald SE/PE DisplayPort™ transmitter, refer to the list below to ensure that you have all the items necessary for installation:

- ◆ Emerald SE/PE DisplayPort transmitter
- ◆ External power supply for the transmitter
- ◆ Power cord
- ◆ PE transmitters only: DisplayPort cable(s) (One DisplayPort cable included for single-head, two DisplayPort cables included for dual-head)
- ◆ PE transmitters only: USB A to USB B device cable
- ◆ Emerald SE/PE DisplayPort Quick Installation Guide (QIG)

NOTE: The Emerald SE DP transmitters do not include any video or USB CPU cables. These cables must be purchased separately.

### 5.6 EMERALD DISPLAYPORT SE AND PE RECEIVERS (EMD2000SE-DP-R, EMD2002SE-DP-R, EMD2000PE-DP-R, EMD2002PE-DP-R) CHECKLIST

Before installing your Emerald SE/PE DisplayPort receiver, refer to the list below to ensure that you have all the items necessary for installation:

- ◆ Emerald SE/PE DisplayPort receiver
- ◆ External power supply for the receiver
- ◆ Power cord
- ◆ Emerald SE/PE DisplayPort Quick Installation Guide (QIG)

### 5.7 EMERALD 4K TRANSMITTER (EMD4000T) CHECKLIST

Before installing your Emerald 4K transmitter, refer to the list below to ensure that you have all the items necessary for installation:

- ◆ Emerald 4K transmitter
- ◆ External power supply for the transmitter
- ◆ Compatible 10 Gbps SFP+ or 1 Gbps SFP
- ◆ Power cord
- ◆ DisplayPort cable
- ◆ USB cable
- ◆ Emerald 4K Quick Installation Guide (QIG)



## CHAPTER 5: INSTALLATION

### 5.8 EMERALD 4K RECEIVER (EMD4000R) CHECKLIST

Before installing your Emerald 4K receiver, refer to the list below to ensure that you have all the items necessary for installation.

- ♦ Emerald 4K receiver
- ♦ External power supply for the receiver
- ♦ Compatible 10 Gbps SFP+ or 1 Gbps SFP
- ♦ Power cord
- ♦ Emerald 4K Quick Installation Guide (QIG)

### 5.9 INSTALLATION OPTIONS



**WARNING:** To reduce the risk of electric shock or damage to your equipment, disconnect the power from the Emerald® device by unplugging the power supply from the electrical outlet. To reduce the risk of electric shock or damage to your equipment, turn on the remote workstation and the Emerald transmitter in the order described in the following procedures.

You can install the Emerald system either in a point-to-point or networked configuration.



**WARNING:** To avoid potentially fatal shock hazard and possible damage to equipment, please observe the following precautions:

- ♦ These devices contain no user-serviceable technology. Do not open the enclosure.
- ♦ Test AC outlets at the workstation and monitor for proper polarity and grounding.
- ♦ Use only with grounded outlets at both the workstation and monitor. When using a backup Uninterruptible Power Supply (UPS), power the workstation and the transmitter from the same supply.

**NOTE:** The AC outlet is the main disconnect.



#### LASER WARNING

**WARNING:** Laser. If using an optical fiber SFP+ adapter when connecting an Emerald to a switch or other device, the user must observe precautions for working with a Class 1 laser product.



The EMD-POE units conform to IEEE802.3af but do not meet the isolation barrier requirements specified in subsection 33.4.1 – Isolation. The units meet the Safety Requirements of IEC 62368.



## CHAPTER 5: INSTALLATION

### 5.10 CONNECT THE EMERALD RECEIVER

The recommended sequence to connect the receiver is:

1. Connect your keyboard, monitor, mouse, and other peripheral cables to the appropriately labeled ports on the Emerald<sup>®</sup> receiver. On the dual-head model, video output #1 is closest to the USB ports on the receiver.
2. Connect the UTP cable to the RJ-45 port, or the fiber cable to the SFP ports, on the back of the receiver.
3. Plug the external power supply's connector into the DC power jack on the rear of the Emerald receiver.
4. Connect the detachable power cord to the power supply.
5. Plug the power cord into an appropriate wall outlet. 2K units automatically power on; 4K units require pressing the latching power button in order to power on.
6. A default connection is available to allow connection to a default Emerald transmitter. You can use the On-Screen Display (OSD) to add a different connection to a remote transmitter or virtual desktop. The default transmitter IP address is 192.168.1.22.
7. Once a Connection has been defined, use the OSD to make connection.

NOTE: VGA or analog video monitors can be connected to the Emerald DVI receiver by using a DVI-D to VGA converter (such as Black Box part number AC1038A).

**CAUTION:** When using PoE to power the Emerald PE receiver, the appliance will supply up to 1 watt of power to attached USB devices. If the connected USB devices consume more than 1 watt in total, you must use the external power supply that was supplied with that specific appliance. The receiver may not operate reliability if excess power is drawn.



# CHAPTER 5: INSTALLATION

## 5.10.1 EMERALD SE RECEIVER CONNECTOR INFORMATION

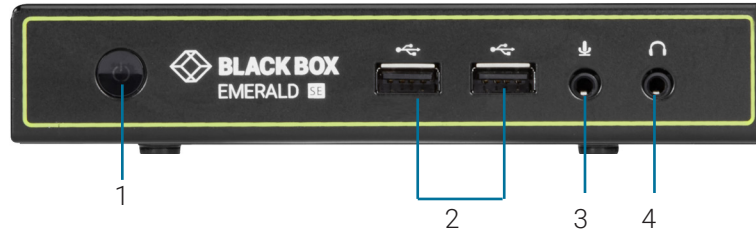

FIGURE 5-1. FRONT VIEW OF EMERALD SE RECEIVER, SINGLE-HEAD (EMD2000SE-R)

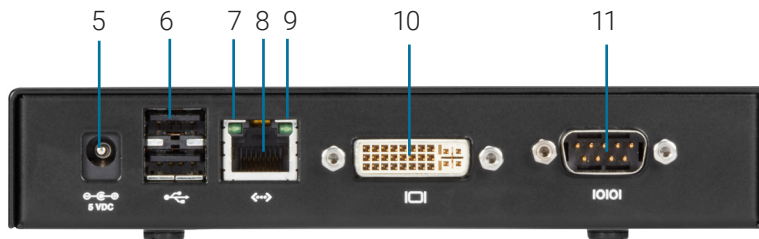

FIGURE 5-2. REAR VIEW OF EMERALD SE RECEIVER, SINGLE-HEAD (EMD2000SE-R)

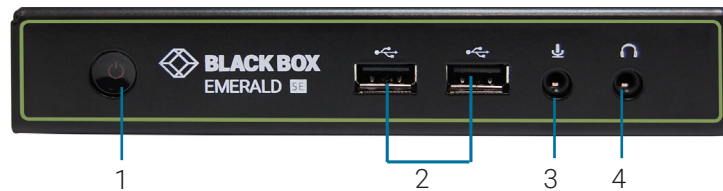

FIGURE 5-3. FRONT VIEW OF EMERALD SE RECEIVER, DUAL-HEAD (EMD2002SE-R)

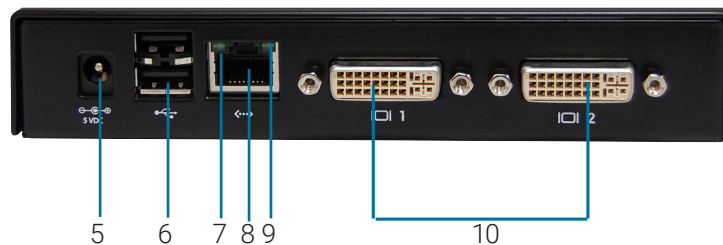

FIGURE 5-4. REAR VIEW OF EMERALD SE RECEIVER, DUAL-HEAD (EMD2002SE-R)

## CHAPTER 5: INSTALLATION

TABLE 5-1. EMERALD SE RECEIVER COMPONENTS

NUMBER IN FIGURES 5-1 THROUGH 5-4	COMPONENT	DESCRIPTION
1	(1) Power button	Disabled. The unit automatically powers on; it must be turned off at the power source.
2, 6	(4) USB Type A connectors	Connects to USB peripherals
3	(1) 3.5-mm jack (MIC)	Connects to analog microphone
4	(1) 3.5-mm jack (SPK)	Connects to analog speaker
5	(1) 2.5-mm barrel (PWR)	Connects to the external 5VDC power supply
7	(1) Link/activity LED	Illuminates green when there is activity on the link
8	(1) RJ-45 connector	Connects to 10-/100-/1000-Mbps network
9	(1) Link speed LED	Illuminates to show link speed; blinks once for 10 Mbps, twice for 100 Mbps, and three times for 1Gbps
10	(1) or (2) DVI output connectors	Connects to DVI output(s) up to 1920x1200
11	(1) DB9 connector*	Connects to RS-232 serial interface

\*Single-head model only



# CHAPTER 5: INSTALLATION

## 5.10.2 EMERALD SE DP RECEIVER CONNECTOR INFORMATION

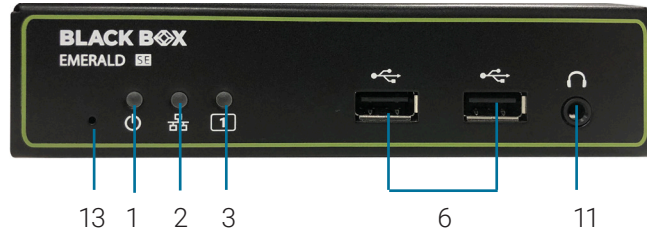

FIGURE 5-5. FRONT VIEW OF EMERALD SE DP RECEIVER, SINGLE-HEAD (EMD2000SE-DP-R)

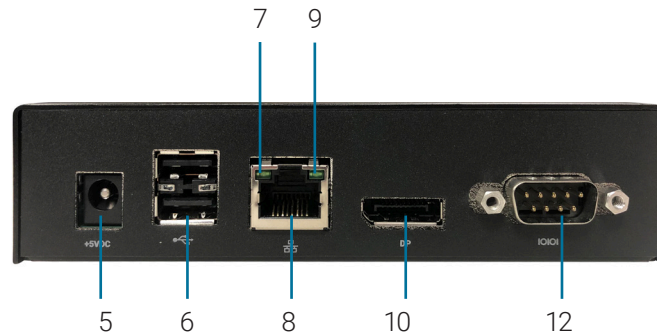

FIGURE 5-6. REAR VIEW OF EMERALD SE DP RECEIVER, SINGLE-HEAD (EMD2000SE-DP-R)

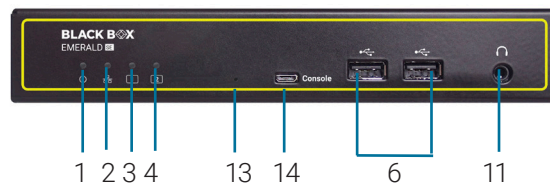

FIGURE 5-7. FRONT VIEW OF EMERALD SE DP RECEIVER, DUAL-HEAD (EMD2002SE-DP-R)

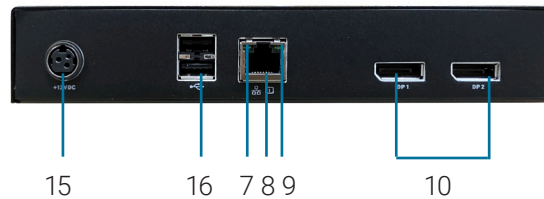

FIGURE 5-8. REAR VIEW OF EMERALD SE DP RECEIVER, DUAL-HEAD (EMD2002SE-DP-R)

## CHAPTER 5: INSTALLATION

TABLE 5-2. EMERALD SE DP RECEIVER COMPONENTS

NUMBER IN FIGURES 5-5 THROUGH 5-8	COMPONENT	DESCRIPTION
1	(1) Power LED	Indicates when the unit is powered up
2	(1) Network LED	Indicates when a network is connected
3	(1) Video 1 Status LED	Indicates when video 1 sync is detected
4	(1) Video 2 Status LED *	Indicates when video 2 sync is detected
5	(1) 2.5-mm barrel (PWR)	Connects to the external 5VDC power supply
6	(2) USB Type A connectors	Connects to USB peripherals
7	(1) Link/activity LED	Illuminates green when there is activity on the link
8	(1) RJ-45 connector	Connects to 10-/100-/1000-Mbps network
9	(1) Link speed LED	Illuminates to show link speed; blinks once for 10 Mbps, twice for 100 Mbps, and three times for 1 Gbps
10	(1) or (2)* DisplayPort™ connectors	Connects to DisplayPort output(s) up to 1920x1200
11	(1) 3.5-mm jack (SPK)	Connects to analog speaker
12	(1) DB9 connector **	Connects to RS-232 serial interface
13	(1) Reset button	Press for 5 seconds to factory reset unit.
14	(1) Micro USB Connector	Reserved for future use
15	(1) 3-pin locking connector (PWR)	Connects to the external 12VDC power supply
16	(2) USB Type A connectors	Connects to USB peripherals

\*Dual-head model only

\*\*Single-head model only



# CHAPTER 5: INSTALLATION

## 5.10.3 EMERALD PE OR PE POE RECEIVER CONNECTOR INFORMATION

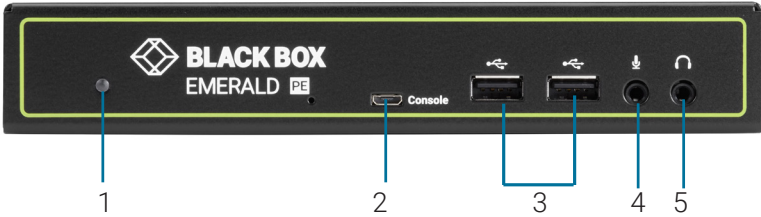

FIGURE 5-9. FRONT VIEW OF EMERALD PE RECEIVER, SINGLE-HEAD (EMD2000PE-R, EMD2000PE-R-P)

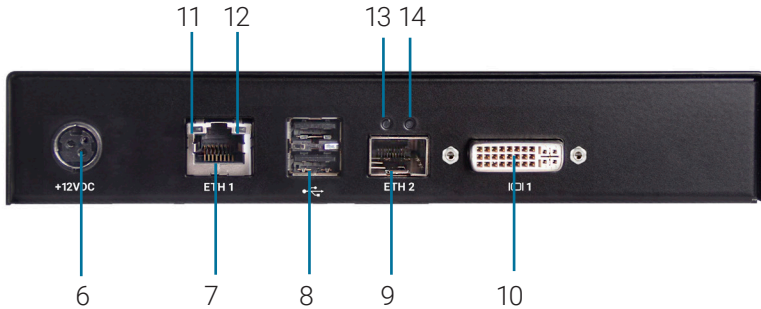

FIGURE 5-10. REAR VIEW OF EMERALD PE RECEIVER, SINGLE-HEAD (EMD2000PE-R, EMD2000PE-R-P)

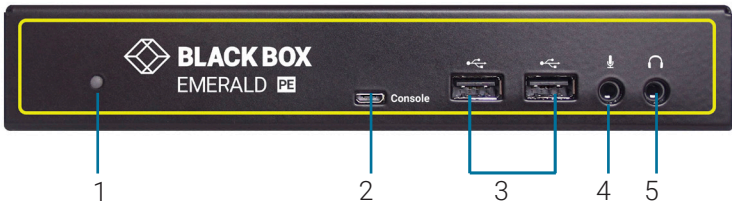

FIGURE 5-11. FRONT VIEW OF EMERALD PE RECEIVER, DUAL-HEAD (EMD2002PE-R, EMD2002PE-R-P)

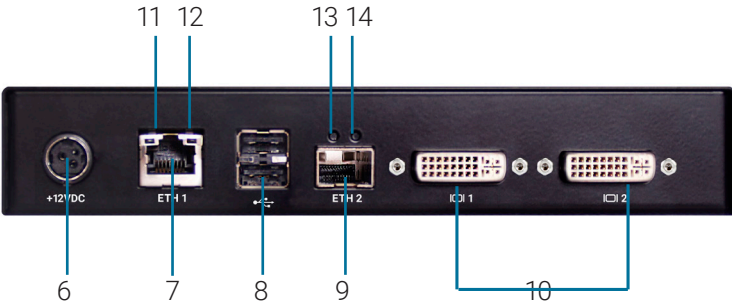

FIGURE 5-12. REAR VIEW OF EMERALD PE RECEIVER, DUAL-HEAD (EMD2002PE-R, EMD2002PE-R-P)

NOTE: EMD2000PE-R and EMD2000PE-R-P look exactly the same from the outside. Similarly, EMD2002PE-R and EMD2002PE-R-P look exactly the same from the outside. The only difference will be the unique device properties, such as part number, serial, and internal PoE component population.

## CHAPTER 5: INSTALLATION

TABLE 5-3. EMERALD PE OR PE POE RECEIVER COMPONENTS

NUMBER IN FIGURES 5-9 THROUGH 5-12	COMPONENT	DESCRIPTION
1	(1) Power LED	Indicates when the unit is powered up
2	(1) Micro USB connector	Reserved for future use
3	(2) USB Type A connectors	Connects to USB peripherals
4	(1) 3.5-mm jack (MIC)	Connects to analog microphone
5	(1) 3.5-mm jack (SPK)	Connects to analog speaker
6	(1) 3-pin locking connector (PWR)	Connects to external 12VDC power supply
7	(1) RJ-45 connector	Connects to 10-/100-/1000-Mbps network
8	(2) USB Type A connectors	Connects to USB peripherals
9	(1) SFP cage	Connects network SFP module for 1 Gbps network
10	(1) or (2) DVI video connectors	Connects to DVI output(s) up to 1920x1200
11	(1) Link/activity LED	Illuminates green when there is activity on the link
12	(1) Link speed LED	Illuminates to show link speed; blinks once for 10 Mbps, twice for 100 Mbps, and three times for 1 Gbps
13	(1) SFP activity LED	Illuminates green when there is activity on the link
14	(1) SFP speed LED	Illuminates to show link speed



# CHAPTER 5: INSTALLATION

## 5.10.4 EMERALD PE SINGLE-HEAD DISPLAYPORT RECEIVER CONNECTOR INFORMATION

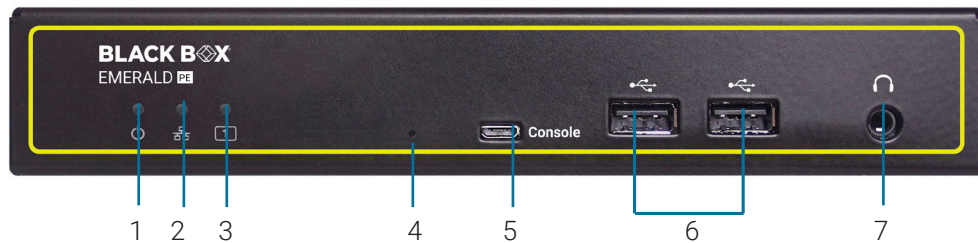

FIGURE 5-13. FRONT VIEW OF THE EMERALD PE RECEIVER, SINGLE-HEAD (EMD2000PE-DP-R)

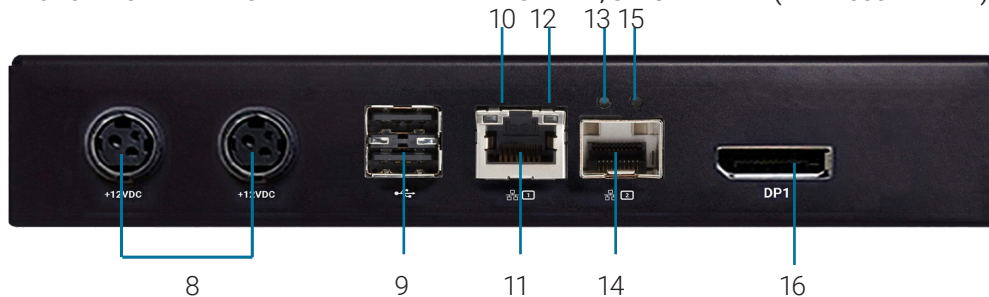

FIGURE 5-14. REAR VIEW OF THE EMERALD PE RECEIVER, SINGLE-HEAD (EMD2000PE-DP-R)

TABLE 5-4. EMERALD PE OR PE POE RECEIVER COMPONENTS

NUMBER IN FIGURES 5-13 THROUGH 5-14	COMPONENT	DESCRIPTION
1	(1) Power LED	Indicates when the unit is powered up
2	(1) Network LED	Indicates when a network is connected
3	(1) Video 1 Status LED	Indicates when video 1 sync is detected
4	(1) Reset button	Press for 5 seconds to factory reset unit.
5	(1) Micro USB connector	Reserved for future use
6	(2) USB Type A connectors	Connects to USB peripherals
7	(1) 3.5-mm jack (MIC)	Connects to 10-/100-/1000-Mbps network
8	(2) 3-pin locking connectors (PWR)	Connects to external 12VDC power supplies
9	(2) USB Type A connectors	Connects to USB peripherals
10	(1) Link/activity LED	Illuminates green when there is activity on the link
11	(1) RJ-45 connector	Connects to 10-/100-/1000-Mbps network
12	(1) Link speed LED	Illuminates to show link speed; blinks once for 10 Mbps, twice for 100 Mbps, and three times for 1 Gbps
13	(1) SFP activity LED	Illuminates green when there is activity on the link
14	(1) SFP cage	Connects network SFP module for 1 Gbps network
15	(1) SFP speed LED	Illuminates to show link speed
16	(1) DisplayPort™ connector	Connects to DisplayPort output(s) up to 1920x1200

# CHAPTER 5: INSTALLATION

## 5.10.5 EMERALD PE DUAL-HEAD DISPLAYPORT RECEIVER CONNECTOR INFORMATION

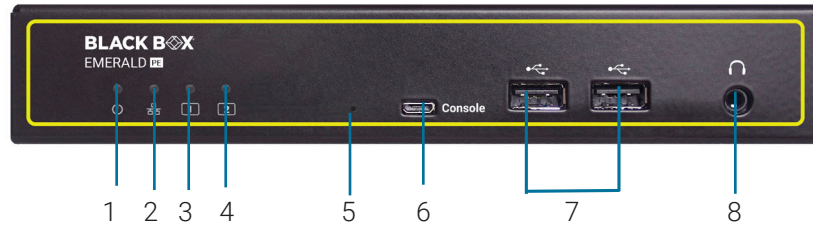

FIGURE 5-15. FRONT VIEW OF THE EMERALD PE RECEIVER, DUAL-HEAD (EMD2002PE-DP-R)

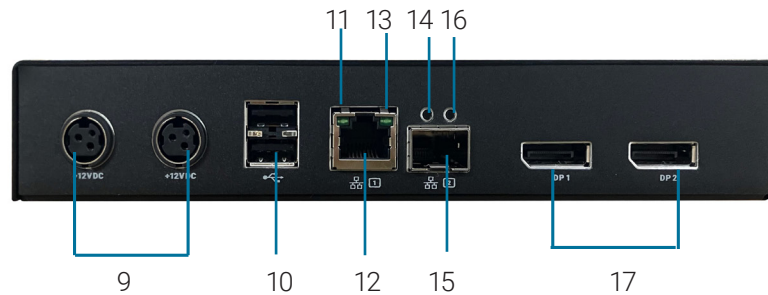

FIGURE 5-16. BACK VIEW OF THE EMERALD PE RECEIVER, DUAL-HEAD (EMD2002PE-DP-R)

TABLE 5-5. EMERALD PE OR PE POE TRANSMITTER COMPONENTS

NUMBER IN FIGURES 5-15 THROUGH 5-16	COMPONENT	DESCRIPTION
1	(1) Power LED	Indicates when the unit is powered up
2	(1) Network LED	Indicates when a network is connected
3	(1) Video 1 Status LED	Indicates when video 1 sync is detected
4	(1) Video 2 Status LED	Indicates when video 2 sync is detected
5	(1) Reset button	Press for 5 seconds to factory reset unit.
6	(1) Micro USB connector	Reserved for future use
7	(2) USB Type A connectors	Connects to USB peripherals
8	(1) 3.5-mm jack (MIC)	Connects to 10-/100-/1000-Mbps network
9	(2) 3-pin locking connectors (PWR)	Connects to external 12VDC power supplies
10	(2) USB Type A connectors	Connects to USB peripherals
11	(1) Link/activity LED	Illuminates green when there is activity on the link
12	(1) RJ-45 connector	Connects to 10-/100-/1000-Mbps network
13	(1) Link speed LED	Illuminates to show link speed; blinks once for 10 Mbps, twice for 100 Mbps, and three times for 1 Gbps
14	(1) SFP activity LED	Illuminates green when there is activity on the link
15	(1) SFP cage	Connects network SFP module for 1 Gbps network
16	(1) SFP speed LED	Illuminates to show link speed
17	(2) DisplayPort™ connectors	Connects to DisplayPort output(s) up to 1920x1200

# CHAPTER 5: INSTALLATION

## 5.10.6 EMERALD 4K RECEIVER CONNECTOR INFORMATION

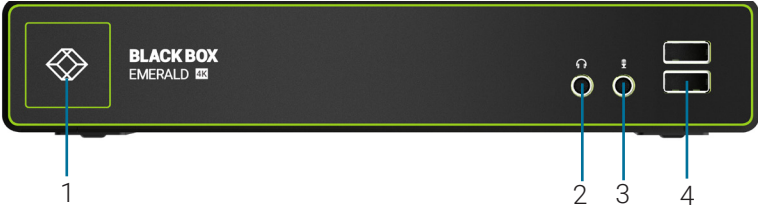

FIGURE 5-17. FRONT VIEW OF EMERALD 4K RECEIVER (EMD4000R)

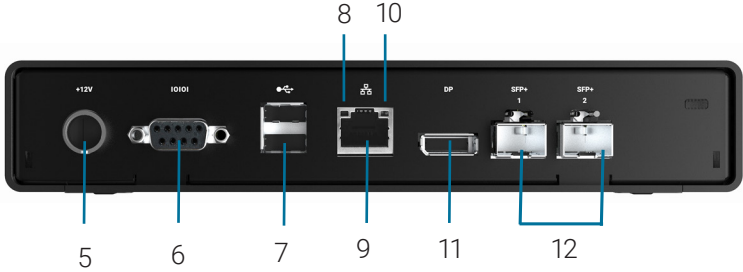

FIGURE 5-18. REAR VIEW OF EMERALD 4K RECEIVER (EMD4000R)

## CHAPTER 5: INSTALLATION

TABLE 5-6. EMERALD RECEIVER COMPONENTS

NUMBER IN FIGURES 5-17 AND 5-18	COMPONENT	DESCRIPTION
1	(1) Power LED	Indicates when the unit is powered up
2	(1) 3.5-mm jack (SPK)	Connects to analog speaker
3	(1) 3.5-mm jack (MIC)	Connects to analog microphone
4	(2) USB Type A connectors	Connects to USB peripherals
5	(1) 3-pin locking connector (PWR)	Connects to external 12VDC power supply
6	(1) DB9 connector	Connects to RS-232 serial console interface for management
7	(2) USB Type A connectors	Connects to USB peripherals
8	(1) Link/activity LED	Illuminates green when there is activity on the link
9	(1) RJ-45 connector	Connects to 10-/100-/1000-Mbps network NOTE: Port not implemented for KVM use.
10	(1) Link speed LED	Illuminates to show link speed; blinks once for 10 Mbps, twice for 100 Mbps, and three times for 1 Gbps
11	(1) DisplayPort™ connector	Connects to DisplayPort output up to 4096 x 2160
12	(2) SFP+ module slots	Twisted-pair or fiber optic modules install here: (2) SFP+ slots (included for redundancy)



## CHAPTER 5: INSTALLATION

### 5.11 CONNECT THE EMERALD TRANSMITTER

Before connecting the Emerald® transmitter to the remote workstation, ensure that the resolution and the refresh rate of the remote workstation are supported by the Emerald system. Set the screen resolution and refresh rate of the remote workstation or, optionally, you can clone the attached monitors' EDID table under Control -> Transmitter -> Preferences. Unsupported settings will cause blank or distorted video at the receiver.

The recommended sequence to connect the transmitter is:

1. Turn off the remote workstation.
2. The Emerald transmitter has one USB connector. Connect it to a corresponding USB port on the remote workstation.
3. Connect the video connector(s) on the Emerald transmitter to the appropriately labeled port on the workstation(s) using the DVI or DisplayPort™ cable(s).
4. Connect one end of the UTP or fiber cable to the Emerald transmitter's RJ-45 or SFP/SFP+ slot and turn on the workstation.
5. Route the other end of the UTP or fiber cable to the location you have chosen for the Emerald receiver. If necessary, you can extend the UTP or fiber cable via an Ethernet switch (subject to normal Ethernet cabling practices).
6. Plug the external power supply's connector into the DC power jack on the rear of the Emerald transmitter.
7. Connect the detachable power cord to the power supply.
8. Plug the power cord into an appropriate wall outlet. 2K units automatically power on; 4K units require pressing the latching power button in order to power on.
9. Turn on power for the remote workstation.

NOTE: Use only the power supply provided by Black Box.



## CHAPTER 5: INSTALLATION

### 5.11.1 EMERALD ZERO DVI AND DP CONNECTOR INFORMATION

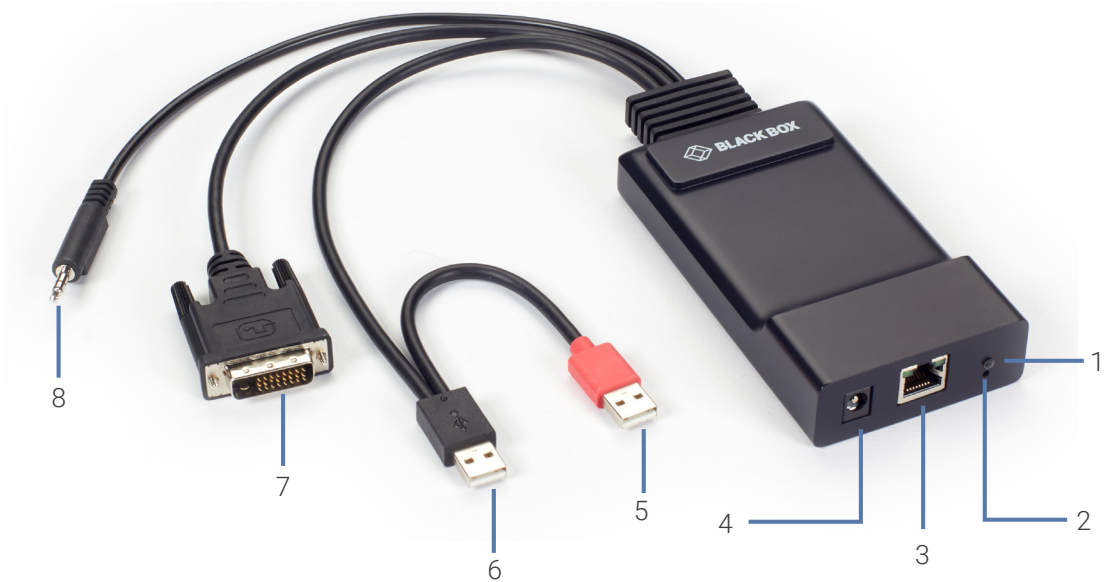

FIGURE 5-19 FRONT VIEW OF THE EMERALD ZERO DVI TRANSMITTER, SINGLE-HEAD (EMD200DV-T)



# CHAPTER 5: INSTALLATION

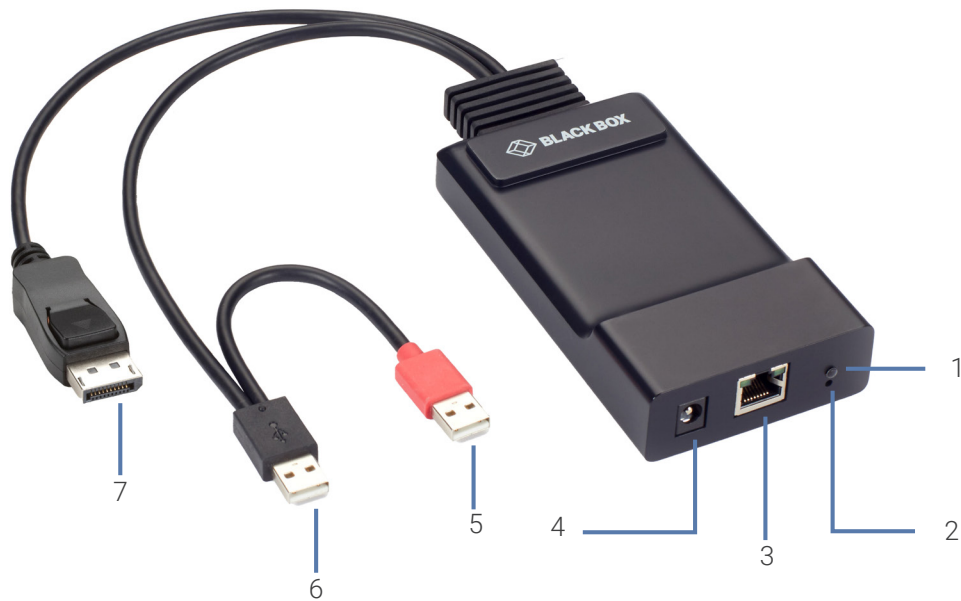

FIGURE 5-20. FRONT VIEW OF THE EMERALD ZEROU DP TRANSMITTER, SINGLE-HEAD (EMD200DP-T)

TABLE 5-7. EMERALD ZEROU DVI OR DISPLAYPORT TRANSMITTER COMPONENTS

NUMBER IN FIGURES 5-19 THROUGH 5-20	COMPONENT	DESCRIPTION
1	(1) Power LED	Indicates when the unit is powered up
2	(1) Reset button	Press for 5 seconds to factory reset unit.
3	(1) RJ-45 connector	Connects to 10-/100-/1000-Mbps network
4	(1) 2.5-mm barrel (PWR)	Connects to external optional 5VDC power supply (not included since transmitter can be powered by USB)
5	(1) USB Type A connector (RED)	Connects to USB port to provide additional power budget; the red plug does not pass keyboard and mouse control. NOTE: Both USB need to be connected to ensure proper function.
6	(1) USB Type A connector (BLACK)	Connects to USB port for keyboard/mouse control NOTE: Both USB need to be connected to ensure proper function.
7	(1) DVI or DisplayPort™ connectors	Links to DVI or DisplayPort output(s) up to 1920x1200
8	(1) 3.5-mm jack (SPK)	Connects to analog speaker (DVI model only)

# CHAPTER 5: INSTALLATION

## 5.11.2 EMERALD SE TRANSMITTER CONNECTOR INFORMATION



FIGURE 5-21. FRONT VIEW OF THE EMERALD SE TRANSMITTER, SINGLE-HEAD (EMD2000SE-T (EOL))

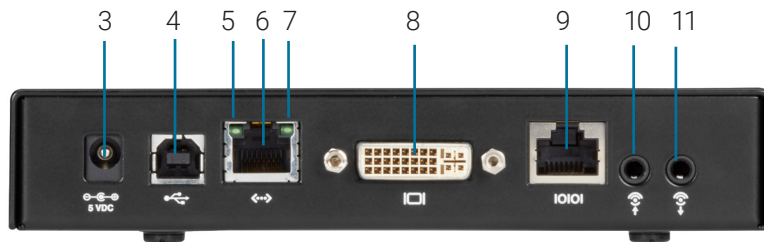

FIGURE 5-22. REAR VIEW OF THE EMERALD SE TRANSMITTER, SINGLE-HEAD (EMD2000SE-T (EOL))



FIGURE 5-23. FRONT VIEW OF THE EMERALD SE TRANSMITTER, DUAL-HEAD (EMD2002SE-T (EOL))

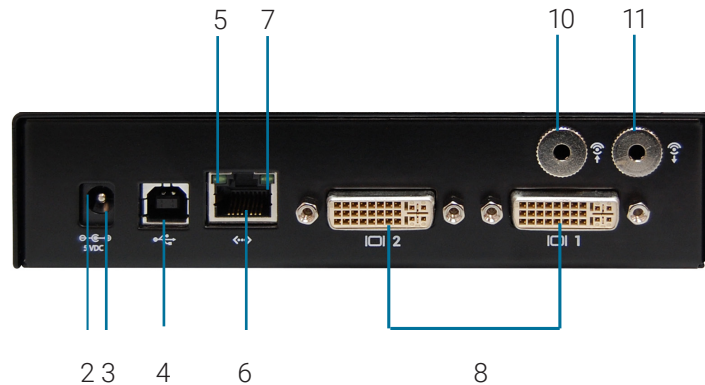

FIGURE 5-24. REAR VIEW OF THE EMERALD SE TRANSMITTER, DUAL-HEAD (EMD2002SE-T (EOL))

## CHAPTER 5: INSTALLATION

TABLE 5-8. EMERALD SE TRANSMITTER COMPONENTS

NUMBER IN FIGURES 5-21 THROUGH 5-24	COMPONENT	DESCRIPTION
1	(1) Power LED	Indicates when the unit is powered up
2	(1) Reset button	Press for 5 seconds to factory reset unit.
3	(1) 2.5-mm barrel (PWR)	Connects to the 5VDC power supply
4	(1) USB Type B connector	Connects to USB port on target PC for keyboard/mouse data
5	(1) Link/activity LED	Illuminates green when there is activity on the link
6	(1) RJ-45 connector	Connects to 10-/100-/1000-Mbps network
7	(1) Link speed LED	Illuminates to show link speed; blinks once for 10 Mbps, twice for 100 Mbps, and three times for 1 Gbps
8	(1) or (2) DVI output connectors	Links to DVI output(s) up to 1920x1200
9	(1) RJ-45 connector*	Connects to RS-232 serial interface
10	(1) 3.5-mm jack (SPK)	Connects to analog speaker
11	(1) 3.5-mm jack (MIC)	Connects to analog microphone

\*Single-head model only



# CHAPTER 5: INSTALLATION

## 5.11.3 EMERALD SE R2 DVI TRANSMITTER, SINGLE-HEAD CONNECTOR INFORMATION

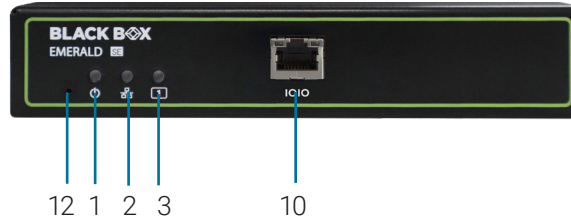

FIGURE 5-25. FRONT VIEW OF THE EMERALD SE R2 DVI TRANSMITTER, DUAL-HEAD (EMD2000SE-T-R2)

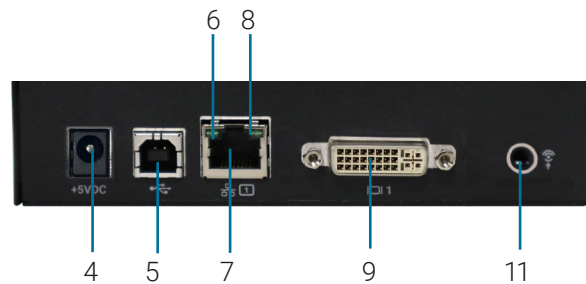

FIGURE 5-26. REAR VIEW OF THE EMERALD SE R2 DVI TRANSMITTER, DUAL-HEAD (EMD2000SE-T-R2)

TABLE 5-9. EMERALD SE TRANSMITTER COMPONENTS

NUMBER IN FIGURES 5-25 THROUGH 5-26	COMPONENT	DESCRIPTION
1	(1) Power LED	Indicates when the unit is powered up
2	(1) Network LED	Indicates when a network is connected
3	(1) Video 1 status LED	Indicates when video 1 sync is detected
4	(1) 2.5-mm barrel (PWR)	Connects to the external 5VDC power supply
5	(1) USB Type B connector	Connects to USB port on target PC for keyboard/mouse data
6	(1) Link/activity LED	Illuminates green when there is activity on the link
7	(1) RJ-45 connector	Connects to 10-/100-/1000-Mbps network
8	(1) Link speed LED	Illuminates to show link speed; blinks once for 10 Mbps, twice for 100 Mbps, and three times for 1 Gbps
9	(1) DVI connector	Connects to DVI output up to 1920x1200
10	(1) RJ-45 connector	Connects to RS-232 serial interface
11	(1) 3.5-mm jack (SPK)	Connects to analog speaker
12	(1) Reset button	Press for 5 seconds to factory reset unit

# CHAPTER 5: INSTALLATION

## 5.11.4 EMERALD SE SINGLE-HEAD DISPLAYPORT TRANSMITTER CONNECTOR INFORMATION

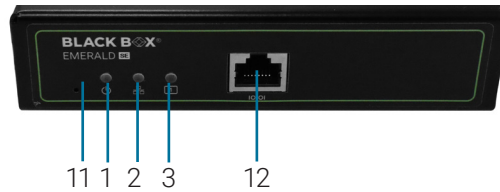

FIGURE 5-27. FRONT VIEW OF THE EMERALD SE TRANSMITTER, SINGLE-HEAD (EMD2000SE-DP-T)

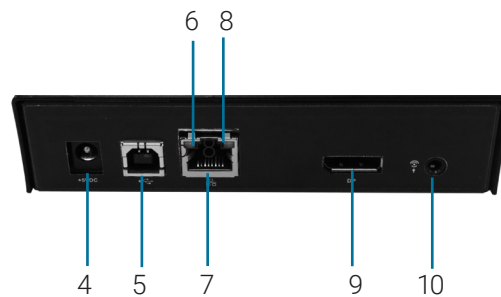

FIGURE 5-28. BACK VIEW OF THE EMERALD SE TRANSMITTER, SINGLE-HEAD (EMD2000SE-DP-T)

TABLE 5-10. EMERALD SE TRANSMITTER COMPONENTS

NUMBER IN FIGURES 5-27 THROUGH 5-28	COMPONENT	DESCRIPTION
1	(1) Power LED	Indicates when the unit is powered up
2	(1) Network LED	Indicates when a network is connected
3	(1) Video 1 status LED	Indicates when video 1 sync is detected
4	(1) 2.5-mm barrel (PWR)	Connects to the external 5VDC power supply
5	(1) USB Type B connector	Connects to USB port on target PC for keyboard/mouse data
6	(1) Link/activity LED	Illuminates green when there is activity on the link
7	(1) RJ-45 connector	Connects to 10-/100-/1000-Mbps network
8	(1) Link speed LED	Illuminates to show link speed; blinks once for 10 Mbps, twice for 100 Mbps, and three times for 1 Gbps
9	(1) DisplayPort™ connector	Connects to DisplayPort output up to 1920x1200
10	(1) 3.5-mm jack (SPK)	Connects to analog speaker
11	(1) Reset button	Press for 5 seconds to factory reset unit
12	(1) RJ-45 connector	Connects to RS-232 serial interface

# CHAPTER 5: INSTALLATION

## 5.11.5 EMERALD SE DUAL-HEAD DISPLAYPORT TRANSMITTER CONNECTOR INFORMATION

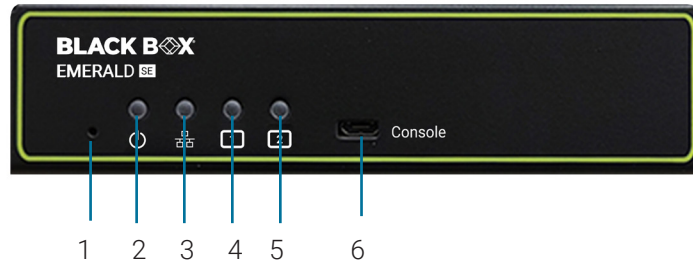

FIGURE 5-29. FRONT VIEW OF THE EMERALD SE TRANSMITTER, DUAL-HEAD (EMD2002SE-DP-T)

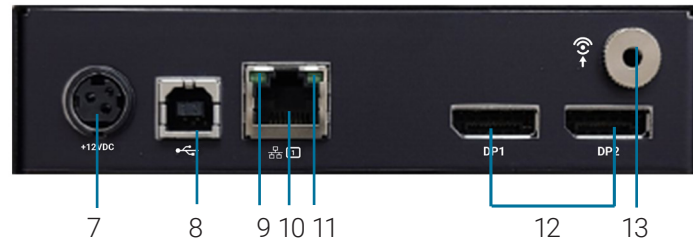

FIGURE 5-30. REAR VIEW OF THE EMERALD SE TRANSMITTER, DUAL-HEAD (EMD2002SE-DP-T)

TABLE 5-11. EMERALD SE DUAL-HEAD DisplayPort TRANSMITTER COMPONENTS

NUMBER IN FIGURES 5-29 AND 5-30	COMPONENT	DESCRIPTION
1	(1) Reset button	Press for 5 seconds to factory reset unit
2	(1) Power LED	Indicates when the unit is powered up
3	(1) Network LED	Indicates when a network is connected
4	(1) Video 1 status LED	Indicates when video 1 sync is detected
5	(1) Video 2 status LED	Indicates when video 2 sync is detected
6	(1) Micro USB connector	Reserved for future use
7	(1) 3-pin locking connector (PWR)	Connects to the external 12VDC power supply
8	(1) USB Type B connector	Connects to USB port on target PC for keyboard /mouse data
9	(1) Link/activity LED	Illuminates green when there is activity on the link
10	(1) RJ-45 connector	Connects to 10-/100-/1000-Mbps network
11	(1) Link speed LED	Illuminates to show link speed; blinks once for 10 Mbps, twice for 100 Mbps, and three times for 1 Gbps
12	(2) DisplayPort™ connectors	Connects to DisplayPort outputs up to 1920x1200
13	(1) 3.5-mm jack (SPK)	Connects to analog speaker

# CHAPTER 5: INSTALLATION

## 5.11.6 EMERALD PE OR PE POE TRANSMITTER CONNECTOR INFORMATION

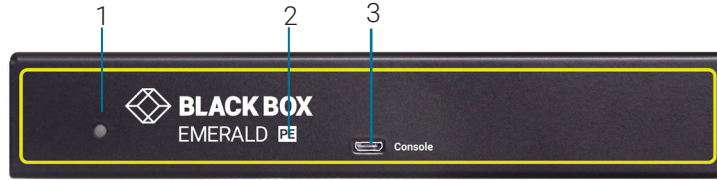

FIGURE 5-31. FRONT VIEW OF THE EMERALD PE TRANSMITTER, SINGLE-HEAD (EMD2000PE-T (EOL), EMD2000PE-T-P (EOL))

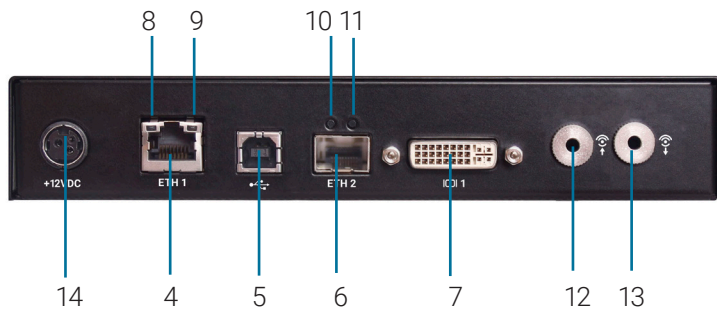

FIGURE 5-32. REAR VIEW OF THE EMERALD PE TRANSMITTER, SINGLE-HEAD (EMD2000PE-T (EOL), EMD2000PE-T-P (EOL))

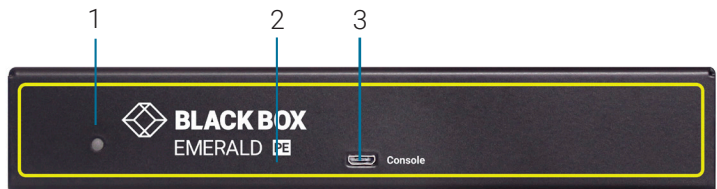

FIGURE 5-33. FRONT VIEW OF THE EMERALD PE TRANSMITTER, DUAL-HEAD (EMD2002PE-T (EOL), EMD2002PE-T-P (EOL))

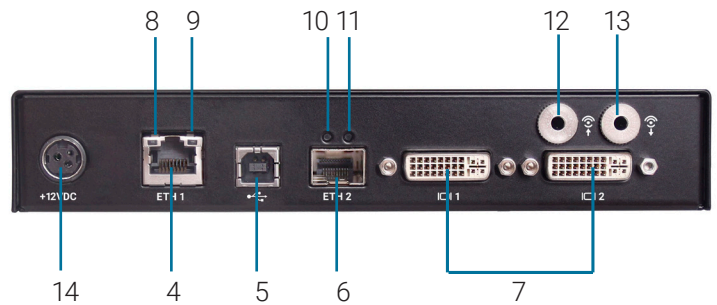

FIGURE 5-34. REAR VIEW OF THE EMERALD PE TRANSMITTER, DUAL-HEAD (EMD2002PE-T (EOL), EMD2002PE-TP (EOL))

## CHAPTER 5: INSTALLATION

TABLE 5-12. EMERALD PE OR PE POE TRANSMITTER COMPONENTS

NUMBER IN FIGURES 5-31 THROUGH 5-34	COMPONENT	DESCRIPTION
1	(1) Power LED	Indicates when the unit is powered up
2	(1) Reset button	Press for 5 seconds to factory reset unit
3	(1) Micro USB connector	Reserved for future use
4	(1) RJ-45 connector	Connects to 10-/100-/1000-Mbps network
5	(1) USB Type B connector	Connects to USB port on target PC for keyboard/mouse data
6	(1) SFP cage	Connects network SFP module for 1 Gbps network
7	(1) or (2) DVI connectors	Links to DVI output up to 1920x1200
8	(1) Link/activity LED	Illuminates green when there is activity on the link
9	(1) Link speed LED	Illuminates to show link speed; blinks once for 10 Mbps, twice for 100 Mbps, and three times for 1 Gbps
10	(1) SFP activity LED	Illuminates green when there is activity on the link
11	(1) SFP speed LED	Illuminates to show link speed
12	(1) 3.5-mm jack (SPK)	Connects to analog speaker
13	(1) 3.5-mm jack (MIC)	Connects to analog microphone
14	(1) 3-pin locking connector (PWR)	Connects to the external 12VDC power supply



# CHAPTER 5: INSTALLATION

## 5.11.7 EMERALD PE R2 SINGLE-HEAD TRANSMITTER CONNECTOR INFORMATION

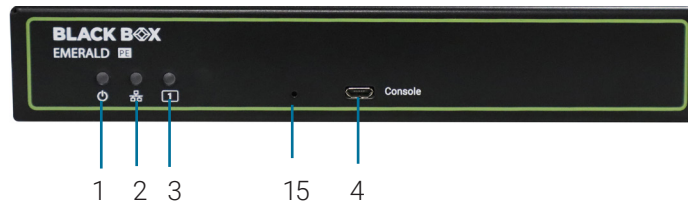

FIGURE 5-35. FRONT VIEW OF EMD2000PE-T-R2

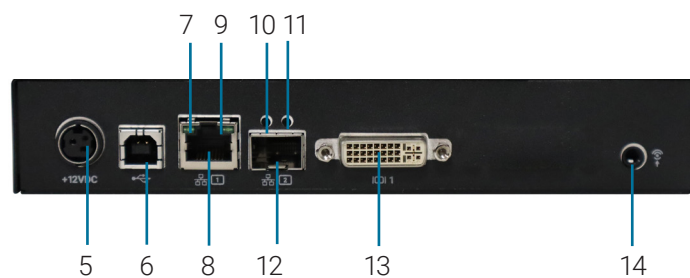

FIGURE 5-36. REAR VIEW OF EMD2000PE-T-R2

TABLE 5-13. EMERALD PE OR PE POE TRANSMITTER COMPONENTS

NUMBER IN FIGURES 5-35 THROUGH 5-36	COMPONENT	DESCRIPTION
1	(1) Power LED	Indicates when the unit is powered up
2	(1) Network LED	Indicates when a network is connected
3	(1) Video 1 status LED	Indicates when video 1 sync is detected
4	(1) Mini USB	Reserved for future use
5	(1) 3-pin locking connector	Connects to the external 12VDC power supply
6	(1) USB Type B connector	Connect to USB port on target PC for keyboard/mouse data
7	(1) Link/activity LED	Illuminates green when there is activity on the link
8	(1) RJ-45 connector	Connects to 10-/100-/1000-Mbps network
9	(1) Link speed LED	Illuminates to show link speed; blinks once for 10 Mbps, twice for 100 Mbps, and three times for 1 Gbps
10	(1) SFP link/activity LED	Illuminates green when there is activity on the link
11	(1) SFP speed LED	Illuminates to show link speed
12	(1) SFP cage	Connects network SFP module for 1 Gbps network
13	(1) DVI connector	Connects to DVI output up to 1920x1200
14	(1) 3.5-mm jack (SPK)	Connects to analog speaker
15	(1) Reset button	Press for 5 seconds to factory reset unit

# CHAPTER 5: INSTALLATION

## 5.11.8 EMERALD PE R2 DUAL-HEAD TRANSMITTER CONNECTOR INFORMATION

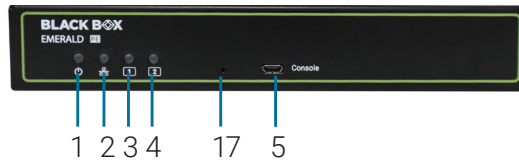

FIGURE 5-37. FRONT VIEW OF EMD2002PE-T-R2

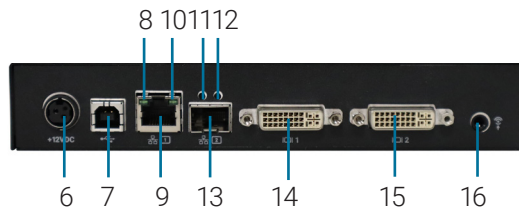

FIGURE 5-38. REAR VIEW OF EMD2002PE-T-R2

TABLE 5-14. EMERALD PE OR PE POE TRANSMITTER COMPONENTS

NUMBER IN FIGURES 5-37 THROUGH 5-38	COMPONENT	DESCRIPTION
1	(1) Power LED	Indicates when the unit is powered up
2	(1) Network LED	Indicates when a network is connected
3	(1) Video 1 status LED	Indicates when video 1 sync is detected
4	(1) Video 2 status LED	Indicates when video 2 sync is detected
5	(1) Mini USB	Reserved for future use
6	(1) 3-pin locking connector (PWR)	Connects to the external 12VDC power supply
7	(1) USB Type B connector	Connects to USB port on target PC for keyboard/mouse data
8	(1) Link/activity LED	Illuminates green when there is activity on the link
9	(1) RJ-45 connector	Connects to 10-/100-/1000-Mbps network
10	(1) Link speed LED	Illuminates to show link speed; blinks once for 10 Mbps, twice for 100 Mbps, and three times for 1 Gbps
11	(1) SFP activity LED	Illuminates green when there is activity on the link
12	(1) SFP speed LED	Illuminates to show link speed
13	(1) SFP cage	Connects network SFP module for 1 Gbps network
14	(1) DVI connector 1	Connects to DVI output 1 up to 1920x1200
15	(1) DVI connector 2	Connects to DVI output 2 up to 1920x1200
16	(1) 3.5-mm jack (SPK)	Connects to analog speaker
17	(1) Reset button	Press for 5 seconds to factory reset unit

# CHAPTER 5: INSTALLATION

## 5.11.9. EMERALD PE SINGLE-HEAD DISPLAYPORT TRANSMITTER CONNECTOR INFORMATION

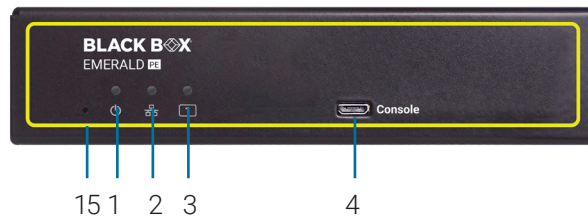

FIGURE 5-39. FRONT VIEW OF THE EMERALD PE TRANSMITTER, SINGLE-HEAD (EMD2000PE-DP-T)

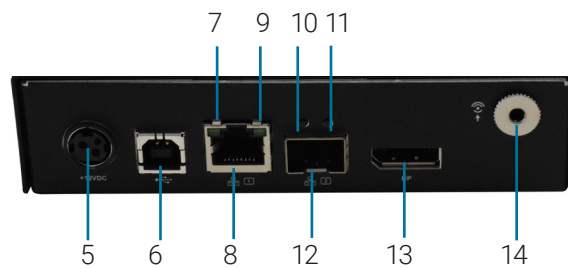

FIGURE 5-40. REAR VIEW OF THE EMERALD PE TRANSMITTER, SINGLE-HEAD (EMD2000PE-DP-T)

TABLE 5-15. EMERALD PE DISPLAYPORT TRANSMITTER COMPONENTS

NUMBER IN FIGURES 5-39 THROUGH 5-40	COMPONENT	DESCRIPTION
1	(1) Power LED	Indicates when the unit is powered up
2	(1) Network LED	Indicates when a network is connected
3	(1) Video 1 status LED	Indicates when video 1 sync is detected
4	(1) Mini USB	Reserved for future use
5	(1) 3-pin locking connector (PWR)	Connects to the external 12VDC power supply
6	(1) USB Type B connector	Connects to USB port on target PC for keyboard/mouse data
7	(1) Link/activity LED	Illuminates green when there is activity on the link
8	(1) RJ-45 connector	Connects to 10-/100-/1000-Mbps network
9	(1) 10-/100-/1000-Mbps LED	Illuminates green when data is being transmitted at 1000 Mbps
10	(1) SFP activity LED	Illuminates green when there is activity on the link
11	(1) SFP speed LED	Illuminates to show link speed
12	(1) SFP cage	Connects network SFP module for 1 Gbps network
13	(1) DisplayPort™	Connects to DisplayPort output up to 1920x1200
14	(1) 3.5-mm jack (SPK)	Connects to analog speaker
15	(1) Reset button	Press and hold for 5 seconds to factory reset unit

# CHAPTER 5: INSTALLATION

## 5.11.10 EMERALD PE DUAL-HEAD DISPLAYPORT TRANSMITTER CONNECTOR INFORMATION

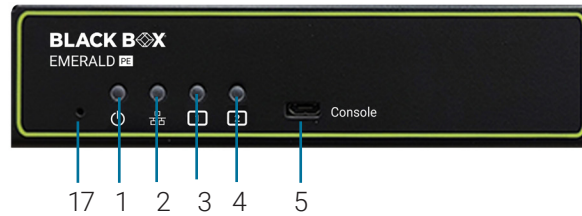

FIGURE 5-41. FRONT VIEW OF THE EMERALD PE TRANSMITTER, DUAL-HEAD (EMD2002PE-DP-T)

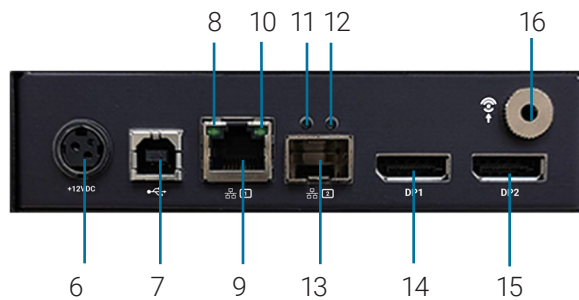

FIGURE 5-42. FRONT VIEW OF THE EMERALD PE TRANSMITTER, DUAL-HEAD (EMD2002PE-DP-T)

TABLE 5-16. EMERALD PE DUAL HEAD DISPLAYPORT TRANSMITTER COMPONENTS

NUMBER IN FIGURES 5-41 THROUGH 5-42	COMPONENT	DESCRIPTION
1	(1) Power LED	Shows the unit's power status
2	(1) Network LED	Indicates when a network is connected
3	(1) Video 1 status LED	Indicates when video 1 sync is detected
4	(1) Video 2 status LED	Indicates when video 2 sync is detected
5	(1) Mini USB	For development use
6	(1) 3-pin locking connector (PWR)	Connects to the external 12VDC power supply
7	(1) USB Type B connector	Connects to USB port on target PC for keyboard/mouse data
8	(1) Link/activity LED	Illuminates green when there is activity on the link
9	(1) RJ-45 connector	Connects to 10-/100-/1000-Mbps network
10	(1) Link speed LED	Illuminates to show link speed; blinks once for 10 Mbps, twice for 100 Mbps, and three times for 1 Gbps
11	(1) SFP activity LED	Illuminates green when there is activity on the link
12	(1) SFP network speed LED	Connects to a 10-/100-/1000-Mbps network using a SFP
13	(1) SFP cage	Connects network SFP module for 1 Gbps network
14	(1) DisplayPort™ connector 1	Connects to DisplayPort output up to 1920x1200
15	(1) DisplayPort connector 2	Connects to DisplayPort output up to 1920x1200
16	(1) 3.5-mm jack (SPK)	Connects to analog speaker
17	(1) Reset button	Press and hold for 5 seconds to factory reset unit

# CHAPTER 5: INSTALLATION

## 5.11.11 EMERALD 4K TRANSMITTER CONNECTOR INFORMATION



FIGURE 5-43. FRONT VIEW OF THE EMERALD 4K TRANSMITTER (EMD4000T)

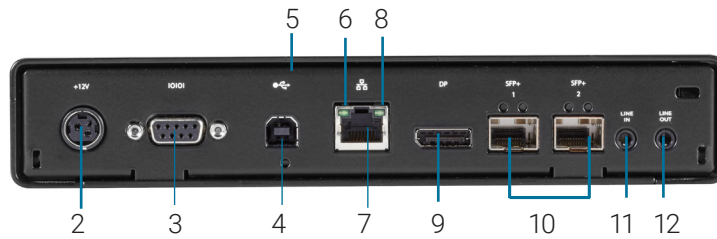

FIGURE 5-44. REAR VIEW OF THE EMERALD 4K TRANSMITTER (EMD4000T)

**TABLE 5-17. EMERALD TRANSMITTER COMPONENTS**

NUMBER IN FIGURE 5-43 AND 5-44	COMPONENT	DESCRIPTION
1	(1) Power LED	Shows the unit's power status
2	(1) 3-pin locking connector (PWR)	Connects to the external 12VDC power supply
3	(1) DB9 connector	Connects to RS-232 serial console interface for management
4	(1) USB Type B connector	Connects to USB port on target PC for keyboard/mouse data
5	(1) Reset button	Press and hold for 5 seconds to factory reset unit
6	(1) RJ-45 connector	Connects to 10-/100-/1000-Mbps networks NOTE: Port not implemented for KVM use.
7	(1) Link/activity LED	Illuminates green when there is activity on the link
8	(1) Link speed LED	Illuminates to show link speed; blinks once for 10 Mbps, twice for 100 Mbps, and three times for 1 Gbps
9	(1) DisplayPort™ connector	Connects to DisplayPort output up to 4096 x 2160
10	(2) SFP module slots	Twisted-pair or fiber optic modules install here: (2) SFP+ slots (included for redundancy)
11	(1) 3.5-mm jack (MIC)	Connects to analog microphone
12	(1) 3.5-mm jack (SPK)	Connects to analog speaker



## CHAPTER 5: INSTALLATION

### 5.12 CONNECT THE EMERALD ZEROU DVI OR DISPLAYPORT TRANSMITTER

Before connecting the Emerald® ZeroU DVI or DisplayPort™ transmitter to the remote workstation, ensure that the resolution and the refresh rate of the remote workstation are supported by the Emerald system. Set the screen resolution and refresh rate of the remote workstation. Unsupported settings will cause blank or distorted video at the receiver.

The recommended sequence to connect the transmitter is:

1. Turn off the remote workstation.
2. The Emerald ZeroU DVI or DisplayPort transmitter has two USB connectors. Connect them to the corresponding USB ports on the remote workstation.
3. Connect the DVI or DisplayPort video connector on the Emerald ZeroU DVI or DisplayPort transmitter to the appropriately labeled port on the workstation using the DVI or DisplayPort cable.
4. Connect one end of the UTP cable to the Emerald ZeroU DVI or DisplayPort transmitter's RJ-45 connector and turn on the workstation.
5. Route the other end of the UTP cable to the location you have chosen for the Emerald SE receiver. If necessary, you can extend the UTP cable via an Ethernet switch (subject to normal Ethernet cabling practices).
6. The Emerald ZeroU DVI or DisplayPort transmitter can be powered via the USB ports. Optionally, plug an external power supply's connector into the DC power jack on the rear of the Emerald SE transmitter.

NOTE: The power supply is not included and must be ordered separately (part number EMD2000-PSU).

7. Optionally, connect the detachable power cord to the power supply.
8. Optionally, plug the power cord into an appropriate wall outlet. The transmitter powers on automatically.
9. Turn on power for the remote workstation.

NOTE: Use only the power supply provided by Black Box.



# CHAPTER 6: NETWORKED INSTALLATION

## 6.1 POINT-TO-POINT INSTALLATION

In a point-to-point configuration, no Administrator setup of the Emerald® transmitter or the Emerald receiver is required. This enables you to install the system quickly, directly out-of-the-box. However, in the point-to-point configuration, you can install only one Emerald transmitter and Emerald receiver pair on a subnet, and both must be on the same subnet unless a router is present in the network to span subnets.

Also if there are other devices with 192.168.1.21 (default receiver IP address) or 192.168.1.22 (default transmitter IP address) on the network, then the IP addresses for receiver and/or transmitter should be changed to unused IP addresses.

## 6.2 UNMANAGED OR MANAGED MATRIX INSTALLATION

The following instructions will enable you to install your Emerald receiver and Emerald transmitter in a networked configuration. In this installation, multiple Emerald transmitters and Emerald receivers are attached via the same Ethernet network. In this case, it is important for each unit to be configured with a unique IP address and 4K transmitters to each have a unique, multicast IP address.

The Emerald receiver has been preconfigured with factory-default network settings. If you install multiple units on the same network, you will need to assign a unique IP address to each unit or configure the receiver for DHCP. This can be done via the On-Screen Display (OSD) on the Emerald receiver and must be carried out before adding multiple devices on the same network. It is strongly recommended that all device IP addresses be configured using a static IP address.

TABLE 6-1. EMERALD SYSTEM DEFAULT NETWORK SETTINGS

COMPONENT	IP ADDRESS	TYPE	DEFAULT GATEWAY	SUBNET MASK
Emerald SE Receiver (EMD2000SE-R, EMD2002SE-R)	192.168.1.21	Static	192.168.1.1	255.255.255.0
Emerald SE Transmitter (EMD2000SE-T, EMD2002SE-T)	192.168.1.22	Static	192.168.1.1	255.255.255.0
Emerald SE R2 Transmitter (EMD2000SE-T-R2)	192.168.1.22	Static	192.168.1.1	255.255.255.0
Emerald PE & SE DisplayPort™ Transmitters (EMD2000PE-DP-T, EMD2000SE-DP-T, EMD2002PE-DP-T, EMD2002SE-DP-T)	192.168.1.22	Static	192.168.1.1	255.255.255.0
Emerald SE & PE DisplayPort Receivers (EMD2000SE-DP-R, EMD2002SE-DP-R, EMD2000PE-DP-R, EMD2002PE-DP-R)	192.168.1.21	Static	192.168.1.1	255.255.255.0
Emerald PE Receiver (EMD2000PE-R, EMD2002PE-R)	192.168.1.21	Static	192.168.1.1	255.255.255.0
Emerald PE PoE Transmitter (EMD2000PE-T, EMD2002PE-T)	192.168.1.22	Static	192.168.1.1	255.255.255.0
Emerald PE PoE Receiver (EMD2000PE-R-P, EMD2002PE-R-P)	192.168.1.21	Static	192.168.1.1	255.255.255.0
Emerald PE R2 Transmitter (EMD2000PE-T-R2, EMD2002PE-T-R2)	192.168.1.22	Static	192.168.1.1	255.255.255.0
Emerald ZeroU DVI Transmitter (EMD200DV-T)	192.168.1.22	Static	192.168.1.1	255.255.255.0
Emerald ZeroU DisplayPort Transmitter (EMD200DP-T)	192.168.1.22	Static	192.168.1.1	255.255.255.0
Emerald 4K Transmitter (EMD4000T)	192.168.1.22	Static	192.168.1.1	255.255.255.0
Emerald 4K Receiver (EMD4000R)	192.168.1.21	Static	192.168.1.1	255.255.255.0
Boxilla Manager (BXAMGR)	192.168.1.24	Static	192.168.1.1	255.255.255.0
Boxilla Manager (BXAMGR-R2)	192.168.1.24	Static	192.168.1.1	255.255.255.0



# CHAPTER 7: OPERATION OF EMERALD SYSTEM

Operating a workstation through the Emerald® system is no different than working directly connected to a PC desktop. All peripherals operate as if directly connected, even though the workstation is located at a distance.

## 7.1 LED IDENTIFICATION

### Front panel

There is a power button on the front panel of an Emerald SE unit. This button is disabled. The Emerald PE unit has a power LED, but it does not have a power button.

NOTE: The SE or PE unit powers on automatically when plugged in, and they must be turned off at the power source.

The Emerald ZeroU DVI or DP transmitter unit has a Power LED. It can be powered either via USB or via an optional power supply.

### Rear panel

Two LEDs are built into the RJ-45 connectors on the Emerald SE receiver, Emerald SE transmitter, and Emerald ZeroU DVI or DisplayPort™ transmitter. The definition of the operation of these LEDs is shown in Table 7-1.

**TABLE 7-1. RJ-45 CONNECTOR LEDS ON THE REAR PANEL OF THE EMERALD SE RECEIVER AND TRANSMITTER**

LED	STATUS	DESCRIPTION
Activity	Green ON	Linked OK
	Green Flashing	Transmit/Receive activity
	Green OFF	No link
Link Speed	Blinks green one time	10 Mbps
	Blinks green two times	100 Mbps
	Blinks green three times	1000 Mbps
	No blinking	No valid link

## 7.2 ACCESSING THE SYSTEM

A connection is established using the On-Screen Display (OSD) on an Emerald receiver or Boxilla® Manager. You will be able to interact with the remote workstation as if it were located at your desk.

NOTE: If the remote workstation is powered OFF, the Emerald system will display a “black” screen for video when a connection is made.



# CHAPTER 8: OSD FUNCTIONS

The Emerald® receiver and Boxilla® Manager incorporate an On-Screen Display (OSD) that allows you to view information about the configuration of your system and potentially also allows for setting connections and configuration parameters such as the IP address, depending on the type of user. The following sections describe the operation common on a receiver.

## 8.1 USER TYPES

The Emerald system supports three classes of users for matrix products:

1. Administrator – users of this class have full rights to configure the system. They can create/modify/delete new users and connections, change network settings, etc.
2. Power User – users of this class can modify resolution for connections to virtual desktops and change his/her local password.
3. Standard User – users of this class can only select from a list of pre-defined connections to access and view system information. They cannot change any configuration settings.

## 8.2 LOG ON

A user must log-on to the Emerald receiver or Boxilla Manager to configure and manage the Emerald system. The log-on screen is shown in Figure 8-1. The username defines the access rights and configuration available to the user.

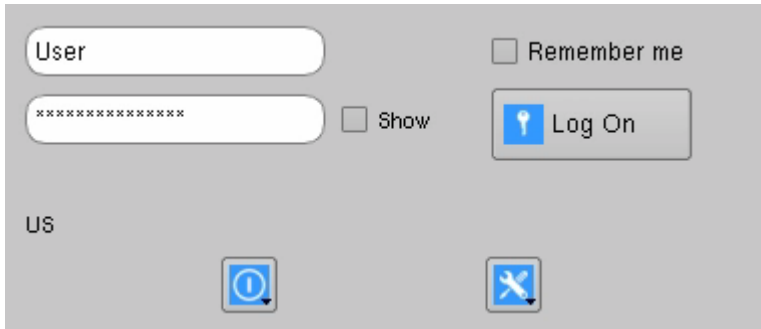

FIGURE 8-1. OSD LOG-ON SCREEN

The fields on this screen are:

- ◆ Username: the username to log-on as defined by the Administrator and/or Active Directory if using the Boxilla manager. Username is case-sensitive. If the username doesn't match an existing Boxilla username, the Active Directory server will be checked afterward.
- ◆ Password: password for the user. Password is case-sensitive.
- ◆ Show: When enabled, the password will be displayed in non hashed characters and readable by anyone who is looking at the screen, as shown in Figure 8-2 below. This option should be used in situations where there are issues logging in and the password needs to be verified before logging in.



FIGURE 8-2. SHOW PASSWORD EXAMPLE

## CHAPTER 8: OSD FUNCTIONS

- ◆ Remember Me: When this box is checked, the unit keeps the username between log-ons and power-cycles. When this box is not checked, the username field is always presented as blank when powered-up and after a log-out. This tick-box only affects the username. The password is never preserved.
- ◆ Log On: When the username and password fields are filled out, pressing this button initiates the login using the entered credentials. Pressing the Enter key when the cursor is positioned in the password field also initiates the log on.
- ◆ Power Button: This button allows the user to reboot the client.



FIGURE 8-3. LOG-ON SCREEN - REBOOT BUTTON

- ◆ System Preferences: This button has a drop down menu that allows the user to define system preferences for the Emerald® receiver. Figure 8-4 shows how the keyboard type can be selected.

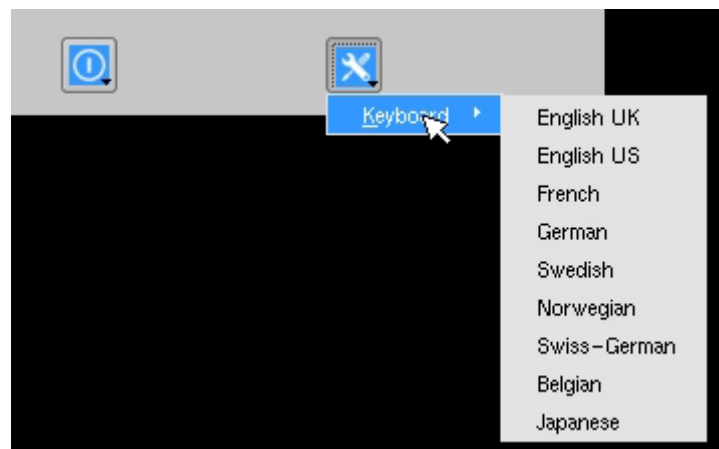

FIGURE 8-4. SETTING SYSTEMS KEYBOARD TYPE

### 8.3 DEFAULT USERNAME AND PASSWORD

The Emerald receiver ships with a default username of admin with a blank password (no password). This user cannot be deleted, but the password can be changed.

**NOTE:** If you create a password for the default Admin account and forget it, there is no way to reset/retrieve it unless using a Boxilla® manager. We recommend that the Administrator creates a second Admin account for critical systems in case the main Admin account is locked out. In the event you still cannot gain access, a factory reset may be required.

# CHAPTER 8: OSD FUNCTIONS

## 8.4 USER VIEWS AND CAPABILITIES

There are three different types of users in the Emerald® System. Your user type will determine what exactly you will see on your OSD. For the purpose of this manual, we show the screen of an Administrator. This means that some buttons shown here may not be available to other users.

The Emerald comes as an unmanaged system and as a managed system. There are some differences in the OSD for these systems which you may see here.

## 8.5 CONNECTIONS SCREEN

When a user successfully logs on to the Emerald receiver, the Connection screen is displayed. This is shown in Figure 8-5. The connections that a user can make are listed in the connection window. The user logged on is shown in the top right corner of the OSD.

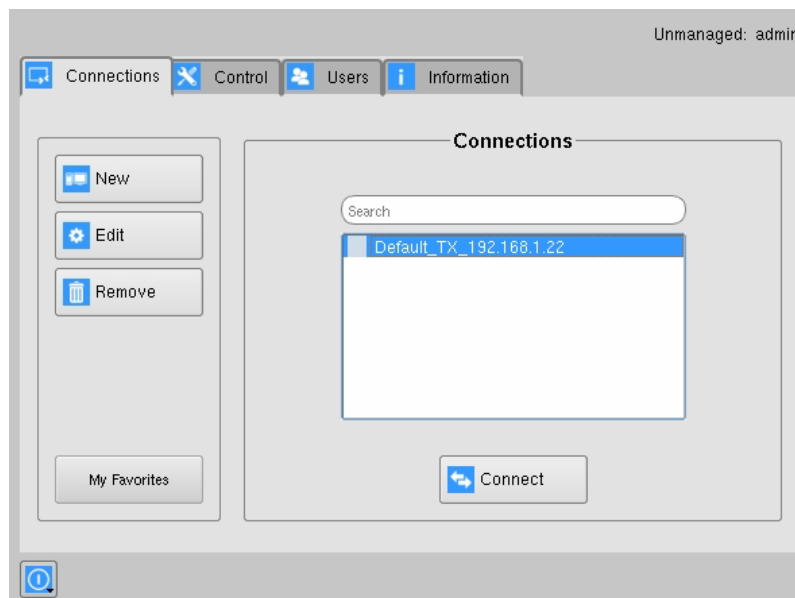

FIGURE 8-5. CONNECTION SCREEN (ADMINISTRATOR)

If the user is an Administrator type, the three buttons on the left (New, Edit, and Remove) will be displayed. These allow the user to create, edit, or remove connections. For standard user types, no connections can be created, edited, or removed, so these buttons are not displayed or are greyed out. The user will also not see the Control, Users, and Information tabs.



## CHAPTER 8: OSD FUNCTIONS

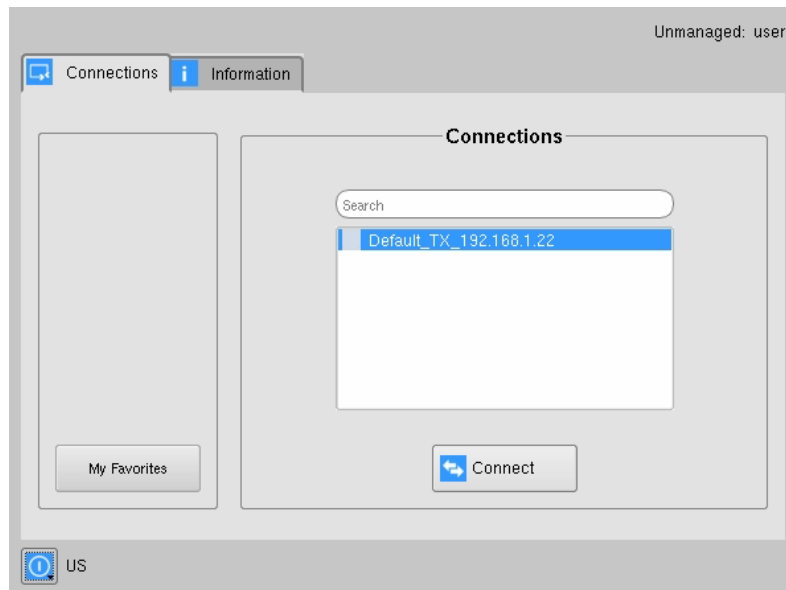

FIGURE 8-6. CONNECTION SCREEN (USERS)

By default, there is one connection called Default TX - 192.168.1.22 that defines a connection to an Emerald® transmitter with its factory defaults. A maximum of 32 connections can be defined for an Emerald receiver by default, and these connections can be shared by users as defined by an Administrator (different users can have the same connection). The number of connections can be increased to unlimited in a managed domain via Boxilla® upgrade licenses. Multiple connections can be created using different parameters for the same physical transmitter. In this example you may have a connection for a 192.168.1.22 transmitter with two connections assigned to it (one with Exclusive, the other Shared).

### 8.5.1 IDLE SCREEN

The Emerald receivers support a static idle screen which allows the user to activate it when using the HOTKEY + S. The static idle screen can be invoked when at the OSD or on an active connection. When you want to go back to the OSD or connection, use the HOTKEY + O.



FIGURE 8-7. WALLPAPER SCREEN

## CHAPTER 8: OSD FUNCTIONS

### 8.5.2 CREATING A NEW CONNECTION

To allow an Emerald® receiver to connect to a target Emerald transmitter, an Administrator must create a connection. The Administrator clicks on the New button on the Connections screen. This causes the New Connections pop-up window to appear as shown in Figure 8-8.

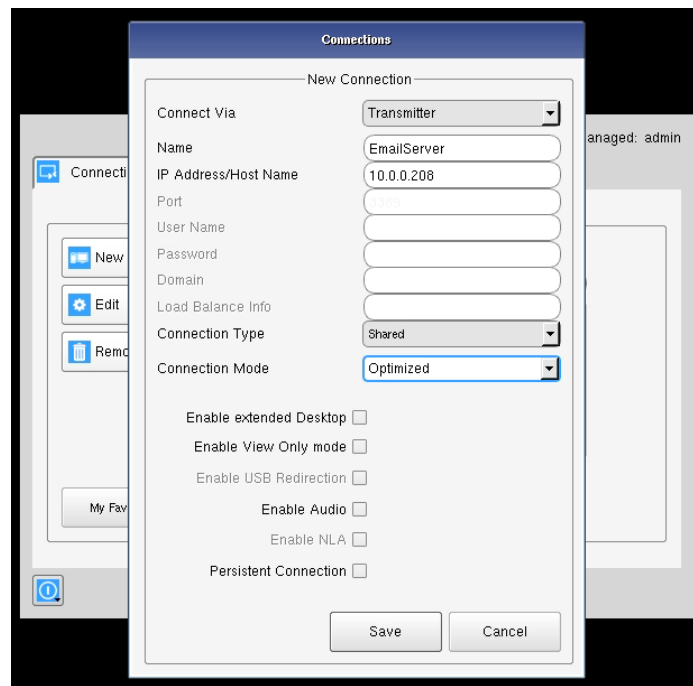

FIGURE 8-8. NEW CONNECTION WINDOW

The fields on this screen are:

- **Connect Via:** This is the connection type that can be set. Options for transmitter or VM Direct are available.
- **Name:** this is a unique name for the new connection. The name can be between 1 and 32 characters. The name can be composed of any alphanumeric characters and special characters except for " / \ [ ] | = , + \* ? < > `".
- **IP Address/Host Name:** IP Address of Emerald transmitter (if Connection Via set to Transmitter) or VM in IP v4 format. Alternatively it can be the Host Name if this can be resolved in the local DNS server. Note: Using Host Name will increase the switching time by the time needed to resolve the Host Name to an IP address.
- **Port:** defines the port to be used for the RDP connection via VM Direct or Broker. Uses port 3389 by default.
- **Username:** defines username to be used on a VM connection. Only used for connections via VM Direct or Broker. If left blank on VM Direct – user will be presented with Windows Login screen on VM; NLA must be turned off if not entering a username here.
- **Password:** defines the password to be used on a VM connection. Only used for connections via VM Direct or Broker.
- **Domain:** defines domain that a virtual machine is part of (if part of a windows domain). Not used for connections to transmitters.
- **Load Balance Info:** Defines resources on the broker (VM Pool that the receiver will attempt to connect to after user credentials have been validated). Only used on connection via Broker.

## CHAPTER 8: OSD FUNCTIONS

- ◆ **Connection Type:** Used to define whether a connection is Private, Shared, or Exclusive. Shared and Exclusive connections can have more than 1 Emerald® receiver connect to it at the same time. Shared connections do not support USB redirection; therefore they do not support USB 2.0 devices except for keyboard, mouse, and select touchscreens. Private connections only allow for a single Emerald receiver connection and blocks any new connections. Private connections support USB redirection for USB 2.0 devices.
- ◆ **Exclusive Connection:** The Boxilla® administrator can define a connection parameter of Exclusive mode for physical transmitters and receivers only. This Exclusive connection (Exclusive Shared connection) allows for a single user to have full keyboard and mouse control while seeing video, and support USB redirection and additional users on the same connection are in view-only mode. This connection can support one user that has full control, and up to 7 view-only-mode users. The view-only-mode users are able to use the keyboard and mouse hot-keys only to go back to the OSD or connect to another target using Favorites without affecting the existing session. If a user connects using “Shared” Exclusive to an existing shared only connection, that user who used the “Shared” Exclusive connection will get keyboard and mouse control, and the other users revert to a view-only mode. Upon terminating a “Shared” Exclusive connection, the remaining active users in that same connection will revert back to shared mode.

Note: Exclusive Connections are supported on every Emerald transmitter and receiver, but not supported on RemoteApp, DESKVUE, or when connecting to a virtual machine.

The image below is only a reference showing all connection options within an unmanaged Emerald OSD.

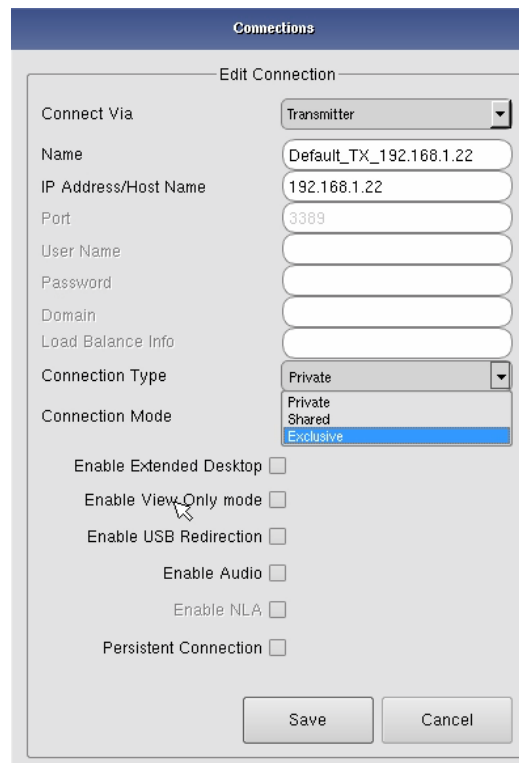

The screenshot shows a dialog box titled "Connections" with a sub-header "Edit Connection". The dialog contains several fields and checkboxes:

- Connect Via:** A dropdown menu set to "Transmitter".
- Name:** A text field containing "Default\_TX\_192.168.1.22".
- IP Address/Host Name:** A text field containing "192.168.1.22".
- Port:** A text field containing "3389".
- User Name:** An empty text field.
- Password:** An empty text field.
- Domain:** An empty text field.
- Load Balance Info:** An empty text field.
- Connection Type:** A dropdown menu set to "Private".
- Connection Mode:** A dropdown menu with options "Private", "Shared", and "Exclusive" (highlighted).
- Enable Extended Desktop:**
- Enable View Only mode:**
- Enable USB Redirection:**
- Enable Audio:**
- Enable NLA:**
- Persistent Connection:**

At the bottom of the dialog are "Save" and "Cancel" buttons.

FIGURE 8-9. CONNECTION OPTIONS

## CHAPTER 8: OSD FUNCTIONS

The image below references the connection parameters when the Emerald device is managed by Boxilla:

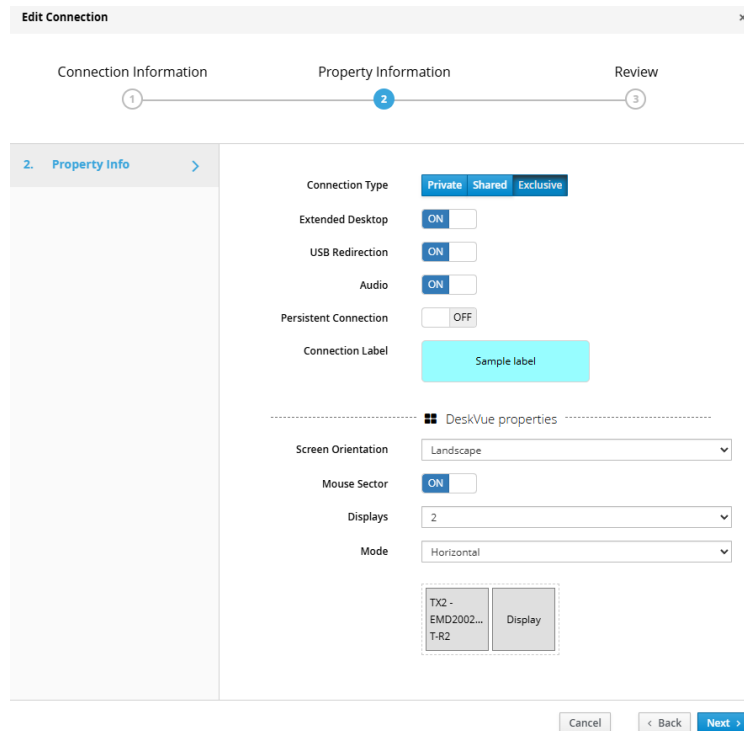

FIGURE 8-10. CONNECTION PARAMETERS

- ◆ **Connection Mode:** There are two options available depending on the device you are using. Optimized connections allows a 2K receiver to connect with a 2K transmitter, or allows a 2K receiver to connect with a 4K transmitter when it is configured for "optimized scaled." Lossless connections allow a 4K receiver to connect with a 4K transmitter only. 2K receivers and RemoteApp will never show any connections with Lossless configuration.
- ◆ **Enable Extended Desktop:** Remote connections can be extended for dual-head Emerald units by enabling the option Extended Desktop. Enable Extended Desktop setting enables the second video head of a dual-head transmitter. Make sure both the video heads on the transmitter are connected to the source. Video heads on the receiver are connected to respective monitors.
- ◆ **Enable View Only mode:** View only setting for a connection allows user to monitor what is being transmitted from a source without being able to interact with the source. This feature allows a user or Administrator to monitor the actions on the network without accidentally interacting with other users. View only connection is available in both private and shared mode connections with or without analog audio.
- ◆ **Enable USB Redirection:** when set, this enables non-keyboard and non-mice devices (such as tablets and USB headsets) to be redirected for this connection. Shared connection modes do not support USB redirection; therefore they only support keyboard and mouse. Private and Exclusive connection modes support USB redirection. ZeroU transmitters (i.e. EMD200DV-T, EMD200DP-T) do not support USB redirection at all.
- ◆ **Enable Audio:** when set, this enables audio to be supplied to the remote audio connectors.
- ◆ **Enable NLA:** when set, this enables Network Level Authentication requiring that the user be authenticated to the RD Session Host server before the session is created. This is not used for when Connection Via is set to Transmitter.



## CHAPTER 8: OSD FUNCTIONS

- ◆ **Persistent Connection:** When turned on, Persistent Connection will constantly try to connect the receiver with the transmitters until successful. This is useful when using Emerald for digital signage or an application that does not need a keyboard/mouse to stay connected to a defined source.
- ◆ **Connection Label:** This is a representation of how the overlay will look on the receiver when making the connection.
- ◆ **Screen Orientation:** This will determine the orientation of the screen when a Deskvue establishes a connection to this device. In Landscape mode, the video output will appear like normal desktops, and, in Portrait mode, it will be turned 90 degrees. If the Portrait mode is enabled and the video is not optimized with the aspect ratio, it will appear compressed.
- ◆ **Mouse Sector:** Can be on or off and determines how the mouse will react when used with multi-head systems.
- ◆ **Displays (only visible when Mouse Sector is enabled):** Configuration for how many displays are being used on DESKVUE.
- ◆ **Mode: (Only visible when Mouse Sector is enabled):** The configuration of the output of the DESKVUE, can be horizontal, vertical, or matrix. The diagram below this setting represents the actual layout to help describe it.

NOTE: Unmanaged Emerald receivers will have limited connection options and are only capable of making Transmitter and Virtual Machine connections. When the Emerald is managed by Boxilla, additional connection options are supported, including TX Pair (Dual-Head Emerald Receiver connecting to two separate Single-Head transmitters with Absolute Mouse mode), Bonded (allows up to 8 Emerald receivers to switch together in a bonded connection), and H.264 (only for DESKVUE receivers).

### 8.5.3 CONNECTION FAVORITES

---

Connection favorites provide a quick convenient mechanism for users to switch between their pre-defined connections. Favorites are configured by the Administrator where a maximum of 10 favorites can be assigned to users using a combination of hot-key and [0-9].

#### Assigning Connection Favorites

Prerequisites are that the user exists; the user has connections assigned; and the Functional Hot-key is enabled.

The following screenshot demonstrates the Administrator assigning connections for the user to the available hot-keys. Favorites do not need to be allocated sequentially and hot-keys can be skipped.



# CHAPTER 8: OSD FUNCTIONS

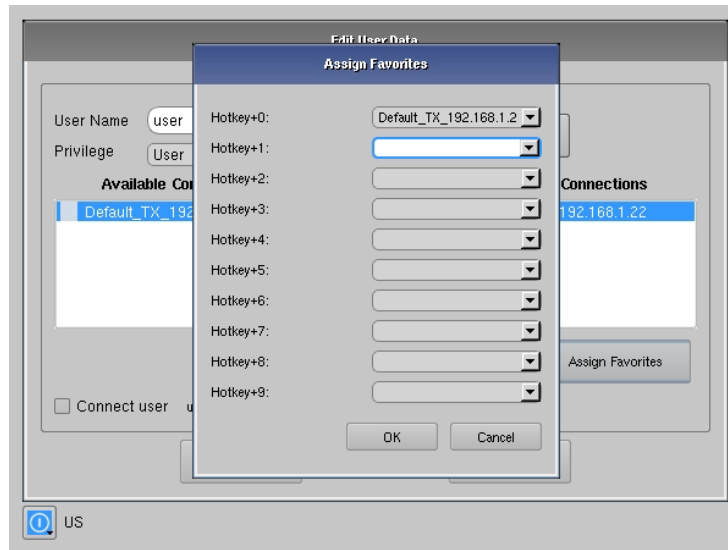

FIGURE 8-11. ASSIGNING CONNECTION FAVORITES

Listing Connection Favorites:

When a user logs in, they can view their assigned favorites.

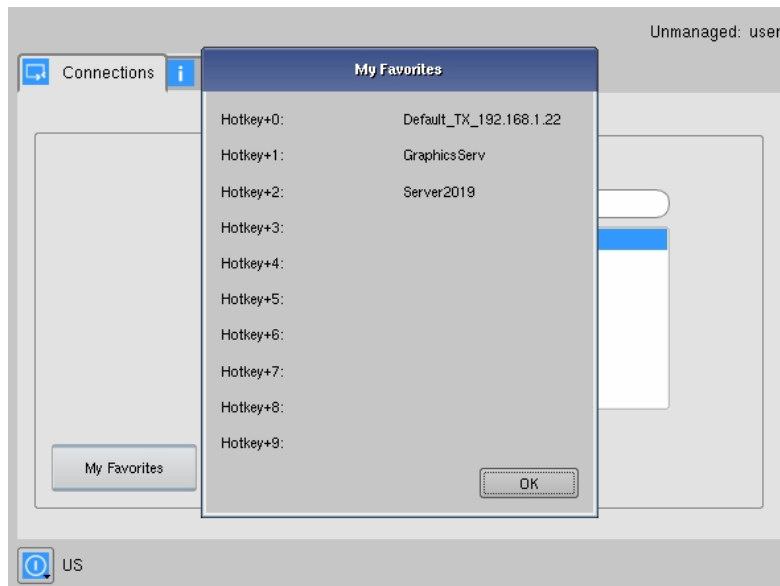

FIGURE 8-12 LISTING CONNECTION FAVORITES

# CHAPTER 8: OSD FUNCTIONS

## 8.5.4 CONNECTION FOLDERS

In an Emerald® environment managed by Boxilla®, the receiver’s “Connections” menu supports enhanced organization through collapsible folders. These folders can be nested up to three tiers deep, allowing you to group connection entries in a logical, hierarchical structure.

Key points:

- Each folder can contain multiple connection names.
- You can name folders according to your preferred conventions, making it easier to categorize connections by function, location, department, or any other relevant criteria.

Flat View Option

If preferred, you can switch to the Flat View layout, which displays all available connections for the logged-in user in a single, scrollable list—without folder grouping.

Search Functionality

Both the folder view and flat view support the built-in search feature, enabling quick access to specific connections regardless of the layout.

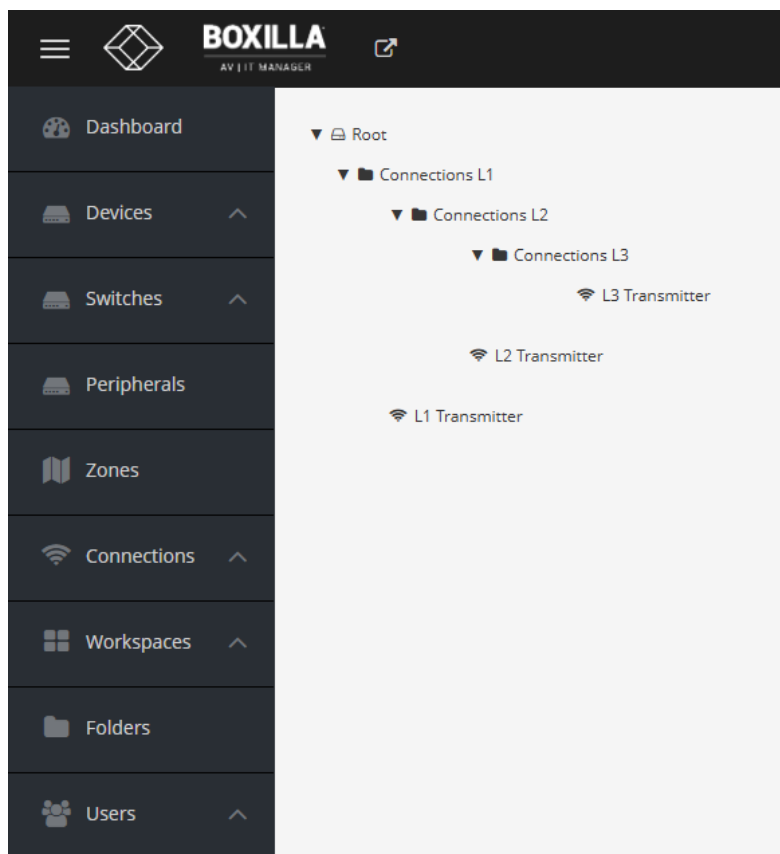

FIGURE 8-13 RECEIVER OSD CONNECTION FOLDER VIEW EXAMPLE



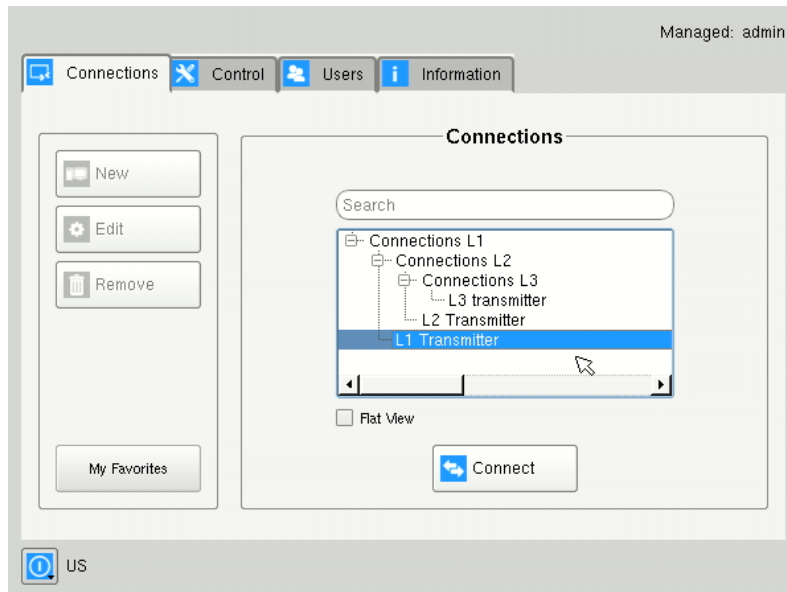

FIGURE 8-14 RECEIVER OSD EXPANDED FOLDER VIEW

Refer to the Boxilla® manual for an in-depth guide on folder configuration.

## 8.5.5 CONNECTING

To make a connection, the user highlights the required “connection” in the window and then clicks on the Connect button. Alternatively, a user can double-click on the connection. This action causes the Emerald® receiver to attempt to connect to the target remote workstation or virtual machine. If the target is available, the connection will be made.

The user can also use the arrow and Enter keys on a keyboard to select a connection.

If another user is already connected to the target using a private connection, the user will receive a pop-up window indicating the target device is already allocated. If connection errors occur, they will be displayed in an error popup window.

## 8.5.6 EDIT CONNECTION

To edit a connection and change its parameters, an Administrator clicks on the Edit button on the Connections screen. The Edit Connections pop-up window appears.

The Administrator changes required fields and clicks on the Save button to confirm or on the Cancel button to discard any changes.

## CHAPTER 8: OSD FUNCTIONS

### 8.5.7 REMOVE CONNECTION

---

To remove or delete a connection, an Administrator highlights a connection in the list and then clicks on the Remove button on the Connections screen (shown in Figure 8-5). This causes the Remove Connection pop-up window to appear where a user confirms the removal or cancels the attempt.

### 8.5.8 BONDING

---

NOTE: Bonding requires the Boxilla® manager.

This assumes that setup is complete on Boxilla and a user has permission to connect to a Bonded connection. See the setup instructions in the Boxilla user manual.

When the user selects a “bonded connection” from any receiver that is part of a bonded group, Receiver 1 will connect to Connection 1, and Receiver 2 will connect to connection 2, and so on, up to 8 bonded links.

Connections will all be made assuming they are available using the normal rules. For example, if one connection is in a private connection and therefore cannot be connected to, all connections within the bond will fail. The user will get an error message from the user station they requested explaining why connection could not be made and will identify the user in private connection.

Once the user has a successful connection, if they disconnect using the OSD, all connections will be terminated.

While the user is in a bonded connection and if they wish to switch one of the receivers to another connection without dropping the full bonded setup, they shall use favorites, and this receiver will switch to the desired target without calling the OSD and leaving all other connections in the bonded connection up and running. The exception to this is that favorites cannot be used from receivers that launched connections via Boxilla.



# CHAPTER 8: OSD FUNCTIONS

## 8.6 CONTROL TAB

The Control Tab on the OSD enables an Administrator to change the configuration of the Emerald® system. The Control Tab is shown in Figure 8-15.

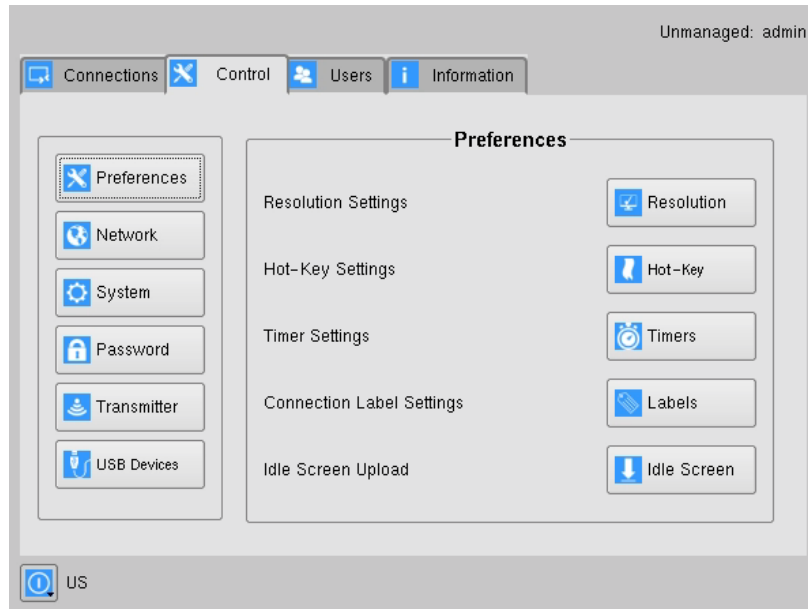

FIGURE 8-15. CONTROL TAB

There are six functions that can be accessed on this tab:

1. Preferences – allows users to change preference settings for:
  - Resolution Settings – allows change of preferred resolution for OSD screens and virtual connections.
  - Hot-Key Settings – allows changing of the active hot-key for keyboard shortcuts.
  - Timer Settings – allows setting of preemption timer and various inactivity timers
  - Connection Label Settings (not applicable to the Emerald® SE Model) – allows activation/deactivation of connection label and set label preferences
  - Idle Screen Upload – The administration has the option to change the idle screen. The dimensions must be 800x600 and must be in .png format.
2. Network – allows the Administrator to change network parameters for the Emerald receiver.
3. System – allows upgrading of unit firmware, reset unit to factory defaults, collect diagnostic logs, and to save/restore unit configuration to a USB drive.
4. Password – change the Administrator or user password.
5. Transmitter – allows changing of transmitter parameters.



# CHAPTER 8: OSD FUNCTIONS

## 8.6.1 PREFERENCES

---

### Resolution

The Resolution button allows an Administrator or power user to set the preferred resolution for the RDP Connection and for the OSD. By default, both the RDP Resolution and the OSD Resolution are set to Auto.

The RDP Connection Resolution allows the resolution to be changed for an RDP connection. For example, it defines the resolution that the virtual desktop will be accessed with. If the preferred resolution is not supported, the receiver will use the next highest resolution supported by both monitor and receiver.

The OSD resolution is set to Auto by default, but can be changed to the available OSD resolutions if the user wants to set a specific resolution. This setting has no effect when connecting to an Emerald transmitter.

Click on the Apply button to save the change.

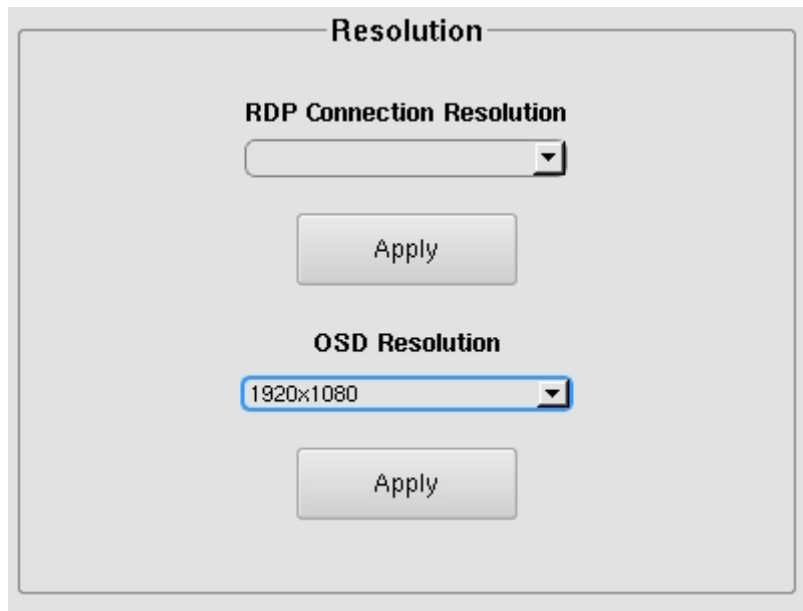

FIGURE 8-16. RESOLUTION SCREEN

# CHAPTER 8: OSD FUNCTIONS

## Hot-Key

This button allows the Administrator to change the hot-key configuration. The hot-key is used with the o key to terminate the current connection and bring up the OSD. The hot-key with p key is used to switch to the previous connection without loading the OSD. Example: PrtScrn, O (default).

The hot-key can be used to initiate the favorites by using the hot-key, # (where # = 0-9 above the main keys and not NUMPAD). In order to support these features the Enable Functional Key needs to be checked/enabled first; otherwise the hot-key functions will be limited to accessing the OSD only.

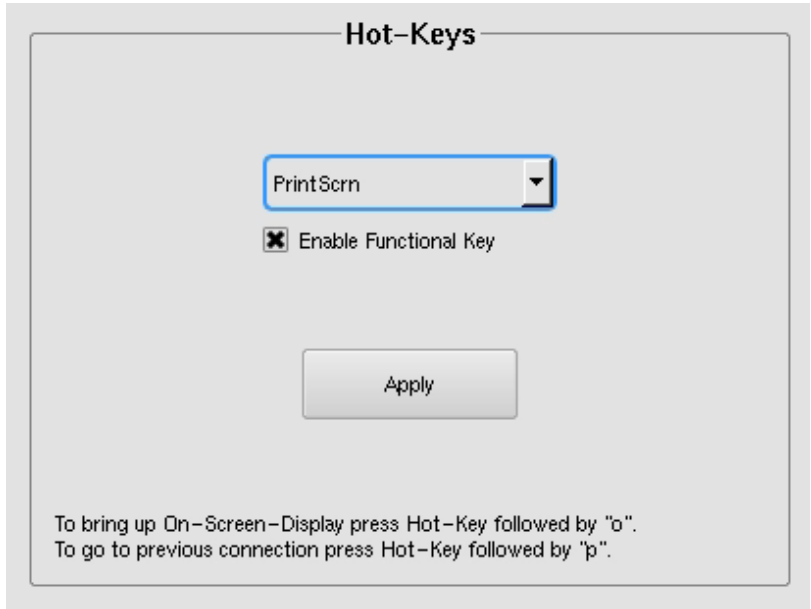

FIGURE 8-17. HOT-KEY DEFINITION

The default hot-key is Print-Screen (PrntScrn). The alternatives are shown in the table. Click the Apply button to confirm a hot-key change.

NOTE: Hot-keys are in sequence, so if your hot-key was set up for Print-Screen and you had Enable Functional Key enabled, you would press PrintScrn, release PrintScrn, Press O, release O, to get to the OSD.

TABLE 8-1. HOT-KEY OPTIONS

HOTKEY OPTION	NOTES
Print Screen	Default
Alt - Alt	
Ctrl - Ctrl	
Shift - Shift	
Mouse Left + Right	



## CHAPTER 8: OSD FUNCTIONS

TABLE 8-2. HOT-KEYS (ENABLE FUNCTIONAL KEY)

SEQUENCE	ACTION
Hot-key only	Nothing
Hot-key, 0	The receiver will close the current connection and bring up the OSD.
Hot-key, P	Connect to the previous target (TIP: This hot-key is good for toggling between two different systems).
Hot-key, # (# = 0-9)	The receiver will connect to the Favorite assigned to the number.

The Enable Functional Key tick-box is used to disable the use of the function keys after the hot-key. So only the Hot-Key is required to bring up the OSD. The Enable Functional Key is enabled by default. If using Favorites, the Enable Functional Key must be enabled.

### Timer Settings

There are two timer settings available to users as shown in Figure 8-18. By default, they are turned OFF. If you wish to turn them ON, you have to select the desired timer, set the time you wish, and click on the Apply button. The two timer settings are:

1. OSD Inactivity Timer – This sets a limit on how long a user can be logged on to the OSD without any keyboard or mouse activity. Once the user reaches the inactivity timer, he/she will be logged out of the OSD. The timer value can be set to a number from 2 to 60 minutes.
2. Connection Inactivity Timer – This sets a limit on how long a user can be connected to a source, such as a virtual machine or transmitter, without any keyboard or mouse activity. Once the session reaches the inactivity timer, he/she will be logged out of their connection and return to the OSD. The timer value can be set to a number from 2 to 60 minutes.

NOTE: Inactivity occurs when the mouse or keyboard is not pressed or moved for a set period of time. The OSD Inactivity Timer and Connection Inactivity Timer can be used together to disconnect a session and log out of the user session.

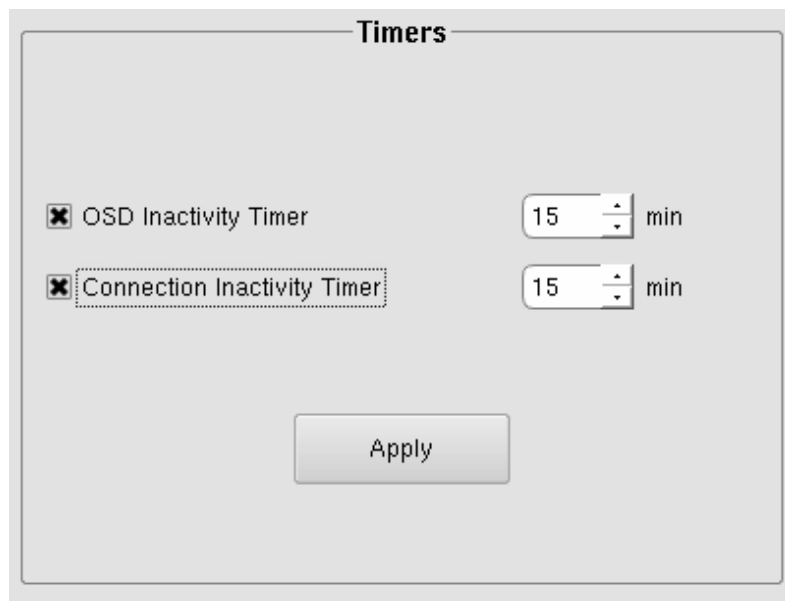

FIGURE 8-18. TIMER SETTINGS

NOTE: The Timers page on the receiver will show additional Local and Global radio buttons when the receiver is managed. Using Local will use the unique receiver settings instead of the global Boxilla settings. Using Global will use the settings defined in Boxilla.

## CHAPTER 8: OSD FUNCTIONS

### Connection Label Settings

The connection label can be enabled to help the user identify what connection is currently being used. This feature can only be enabled per receiver station by a power user or an Administrator user. By default, the feature is OFF, and the user can enable it and set the label to stay for 5 seconds after a connection or stay on screen permanently.

Note: This feature is available on all Emerald® receivers with the exception of the EMD2002SE.

By using their hot-key and pressing L, the user can toggle the label ON or OFF. In Figure 8-19, the Connection Label is enabled.

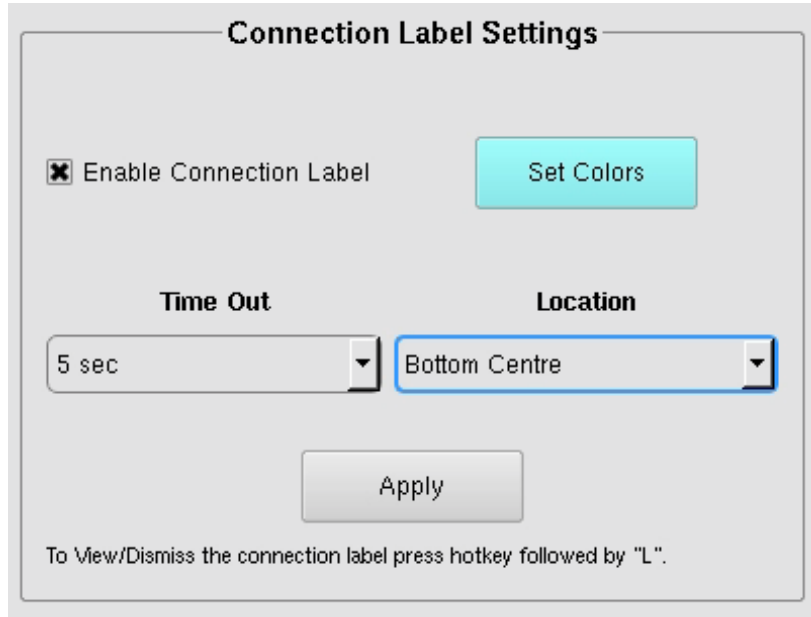

FIGURE 8-19. CONNECTION LABEL OPTION ENABLED

# CHAPTER 8: OSD FUNCTIONS

The user can select to always display the connect label or to display it for 5 seconds. In Figure 8-20, a 5-second time out is selected.

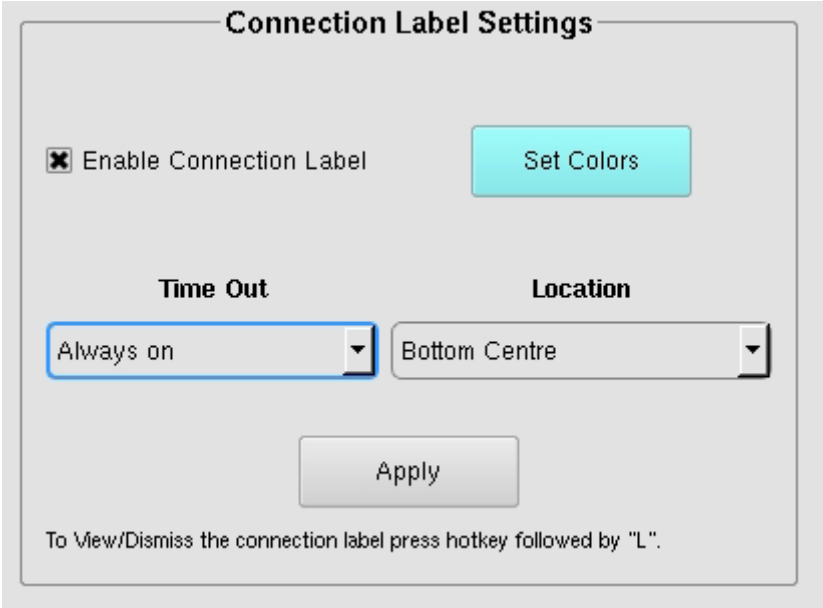

FIGURE 8-20. CONNECTION LABEL TIME OUT OPTIONS

The user can also select where the label will appear on the screen. In Figure 8-21, Bottom Centre is selected for the location.

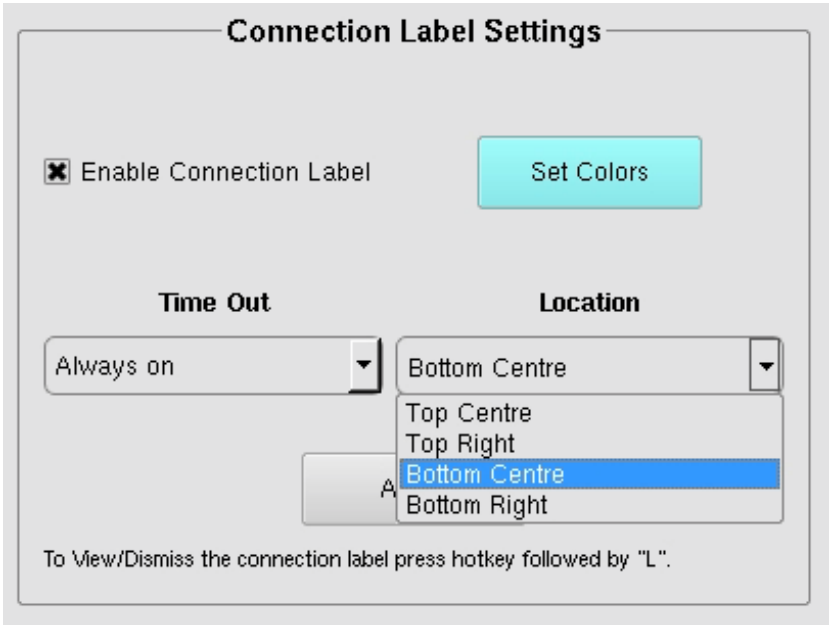

FIGURE 8-21. CONNECTION LABEL LOCATION OPTIONS

## CHAPTER 8: OSD FUNCTIONS

Figure 8-20 shows the connection label located in the bottom center of the screen, based upon the location selected in Figure 8-22.



FIGURE 8-22. CONNECTION LABEL SHOWN IN BOTTOM CENTER OF SCREEN



## CHAPTER 8: OSD FUNCTIONS

### 8.6.2 NETWORK

The network screen shown in Figure 8-18 allows an Administrator to change the settings for the Emerald® receiver. The default network setting for the receiver is a static IP address of 192.168.1.21. It has a network mask of 255.255.255.0 and a Gateway 192.168.1.1. If DHCP is selected, the receiver gets its IP address from the DHCP server. Click on the Apply button to confirm any changes to network settings.

NOTE: We strongly recommend using Static IP addresses on the receivers. Also, only IPv4 addressing is supported in the current firmware version.

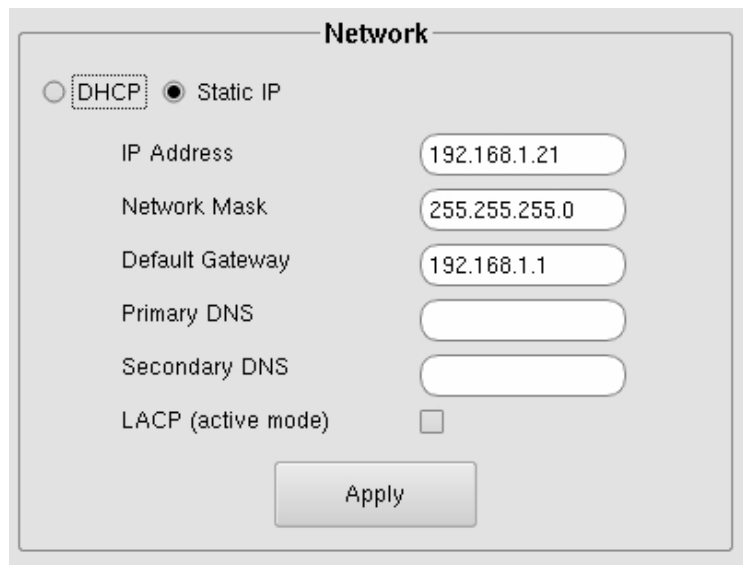

The screenshot shows a web-based configuration interface for network settings. At the top, the title "Network" is centered. Below the title, there are two radio buttons: "DHCP" (which is currently unselected and has a dashed border) and "Static IP" (which is selected). Underneath these are several rows of configuration options, each with a text label on the left and an input field on the right. The "IP Address" field contains "192.168.1.21", "Network Mask" contains "255.255.255.0", and "Default Gateway" contains "192.168.1.1". The "Primary DNS" and "Secondary DNS" fields are empty. At the bottom of the form is a checkbox labeled "LACP (active mode)" which is unchecked. Below the entire form area is a large, light-colored button labeled "Apply".

FIGURE 8-23. NETWORK SETTINGS

# CHAPTER 8: OSD FUNCTIONS

## 8.6.3 SYSTEM

The System screen shown in Figure 8-24 allows an Administrator to upgrade the firmware in the Emerald® receiver, reset it to factory defaults, import/export the configuration to an external USB drive, and compile/export system diagnostic information.

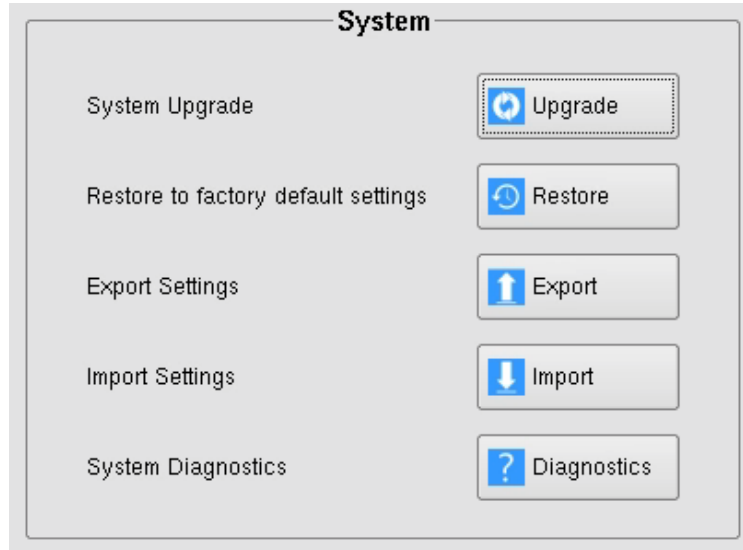

FIGURE 8-24. SYSTEM SCREEN

### System Upgrade

The Emerald receiver can be upgraded using a FAT32-formatted USB flash drive. Simply take the firmware file and place it in the root directory of the flash drive. When you click the Upgrade button, the valid upgrade files on the USB drive are displayed. A valid file has the extension .clu – an example is shown in Figure 8-23. NOTE: There can only be one USB key/flash drive inserted in the receiver, and that key must contain the upgrade files. If the user has two keys inserted, and the second key has the upgrade files, the system will not locate the required files.

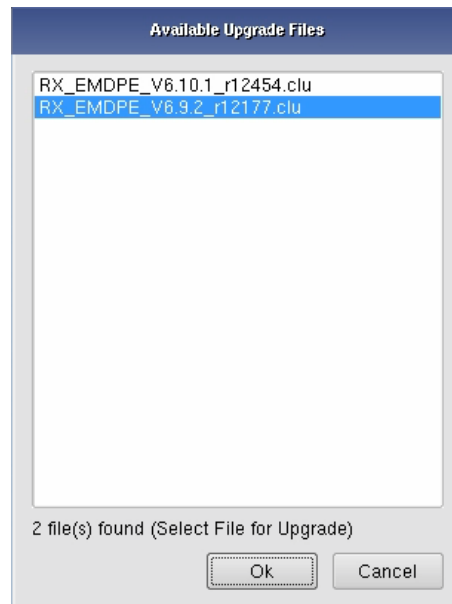

FIGURE 8-25. UPGRADE FILES



## CHAPTER 8: OSD FUNCTIONS

If there is only one upgrade file on the flash drive, you will not be presented with a prompt confirming the firmware since there is only one choice.

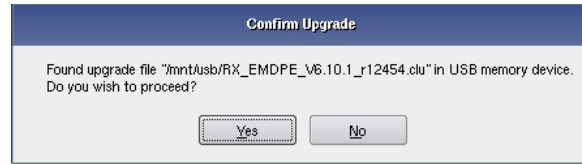

FIGURE 8-26. CONFIRMATION SCREEN

Once the Administrator has selected the file and confirmed the upgrade by clicking on the Yes button, the system checks that the selected file has no errors before upgrading the Emerald® receiver. The configuration of the unit is preserved through the upgrade.

When upgrading unmanaged Emerald devices from versions older than 6.x, the upgrade process requires multiple step up upgrades to get to the latest version. If using Boxilla® to perform the upgrades, the process can usually be done in one step.

NOTE: Always update the transmitter first before the receiver. Failure to upgrade the transmitter first can result in problems, including not being able to re-establish the connection in rare cases. The receiver cannot be downgraded. For example, once you upgrade to 6.2 on SE receivers, you can no longer downgrade to an earlier version.

### Restore Factory Defaults

The Administrator can click the Restore button to reset the receiver back to factory defaults.

### Export

This option is used in conjunction with Import. It will export the current receiver configuration to an external flash drive so that you can load it on another receiver in an unmanaged system. This option is good for users who want to configure users, connections, and system settings on one receiver and then apply it to other receivers without having to manually type everything in again.

### Import

This option is used in conjunction with Export. It allows the administrator to import a configuration that includes users, connections, and system settings onto a receiver in unmanaged systems. This option is good for applications where the administrator needs to create a setup and apply the same settings to multiple receivers.

### System Diagnostics

The diagnostics provides information for Black Box to debug customer encountered issues. When this button is clicked, the user is asked to save the diagnostics onto a memory stick in the receiver unit. Send this file to Black Box for analysis.

There is a similar diagnostic that can be run on a transmitter. Depending on the firmware version of the transmitter and receiver, the Diagnostics button may not be available if the device is managed by Boxilla. To get the logs from a managed system, go to the Boxilla dashboard under Devices --> Manage and click the ellipsis (...) next to the device. Then click on Retrieve Logs and follow the on-screen instructions.

## CHAPTER 8: OSD FUNCTIONS

**TIP:** When issues occur, compile and diagnostics as soon as possible and report the problem to Black Box so we can investigate. The longer you wait to collect the logs, the higher the risk is that they will be overwritten. Normal logs can be overwritten after 3-4 days of operation. Providing logs from both the transmitter and receiver devices when reporting a problem to technical support will help to resolve the issue.

The logs are encrypted for your protection so that nobody can collect any system data if the log file was obtained by an unauthorized person. Only Black Box specialists can decrypt and review the log files.

### Password

When clicked, the Password button allows the current user's password to be changed. This button is only visible to Administrators.



FIGURE 8-27. PASSWORD CHANGE

### Transmitter Button

The Transmitter button on the Control Tab allows Administrators to change the configuration of an Emerald® transmitter. This button is only visible to Administrators.

The following options are available when the Transmitter button has been activated:

1. Transmitter Information
2. Transmitter Firmware Upgrade
3. Transmitter restore factory defaults
4. Transmitter reboot
5. Network Settings
6. Discover Transmitter IP Address
7. Transmitter Preferences
8. Transmitter Diagnostics

### Configuring a Transmitter

To configure a transmitter, the IP address must be defined for the target transmitter. When there is no active IP address defined, the Transmitter Setting window has all the buttons grayed out except for the Apply and Discover buttons.

Enter the IP address for the transmitter into the field at the top of window and click on the Apply button to activate. If a valid IP address is entered, the Transmitter Settings window makes all the options available for the Administrator shown in Figure 8-28.

Alternatively the Discover button can be used to find the IP address of a transmitter. First click on the Discover button and follow the instructions. Basically, once in discovery mode, the receiver (or Boxilla® Manager) can capture the IP address from a transmitter once it has been power-cycled.



## CHAPTER 8: OSD FUNCTIONS

NOTE: The default network setting for the transmitter is a static IP address of 192.168.1.22. It has a network mask of 255.255.255.0 and a Gateway 192.168.1.1.

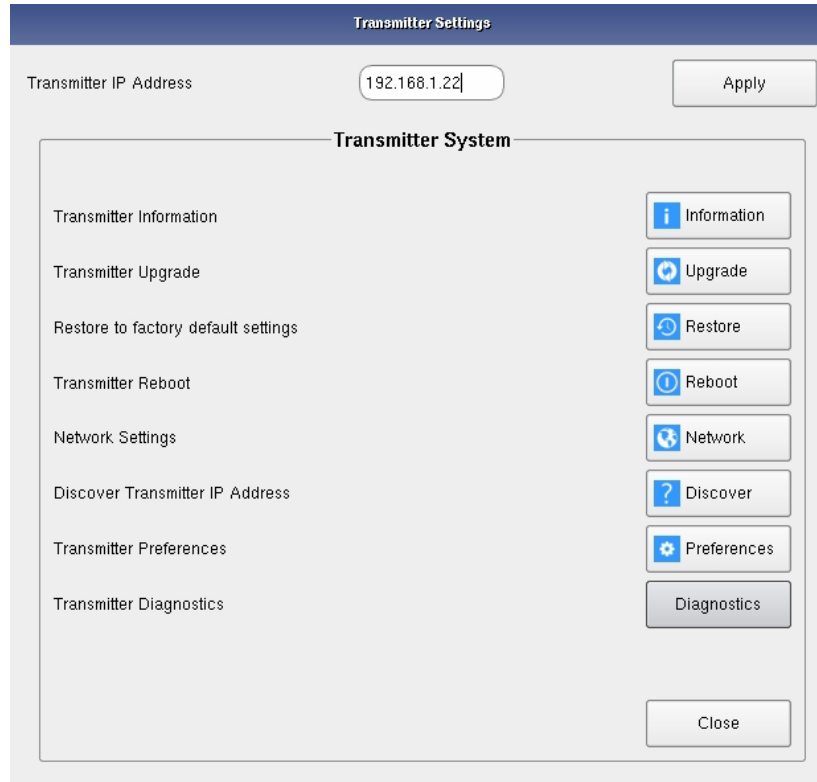

FIGURE 8-28. TRANSMITTER SETTINGS CONFIGURATION WINDOW - ACTIVE IP ADDRESS

If the IP address of the receiver and transmitter are not on the same subnet, a router is required to allow them to communicate. This is true even when the receiver discovers the transmitter's IP address. One way to avoid this is to change the receiver address to be on the same subnet as the transmitter, make the required configuration changes to the transmitter, and then change the receiver back to its required IP address.

### Transmitter Information

The Information button provides transmitter related information, such as device model, serial number, MAC address, and current firmware version, to the Administrator.

If the active IP address is not the address of a valid Emerald® transmitter or this address is unreachable, an error message is returned.

## CHAPTER 8: OSD FUNCTIONS

### Transmitter Upgrade

The Administrator can click on the Upgrade button to change the firmware on a transmitter. The upgrade file is selected from the set of files on an attached USB drive. These files will have the extension .clu . The selected file is checked to be a valid transmitter upgrade file before starting the upgrade. The OSD provides a series of screens to walk the user through the process.

The upgrade can take a few minutes to complete and the power to the transmitter, and the receiver must not be disconnected during the upgrade. During the upgrade process, the transmitter may reboot.

If the active IP address is not the address of a valid Emerald transmitter or this address is unreachable, an error message is returned.

### Restore to Factory Default Settings

The Administrator can click the Restore button to reset the transmitter back to factory defaults. If the active IP address is not the address of a valid Emerald transmitter or this address is unreachable, an error message is returned. Depending upon the firmware version and if the device is managed, this button may not be available on the receiver menu. In managed systems, access this option through the Boxilla dashboard.

### Transmitter Reboot

The Administrator can click on the Reboot button to power-cycle the transmitter. If the active IP address is not the address of a valid Emerald transmitter or this address is unreachable, an error message is returned.

### Network Settings

The Administrator can click the Network Settings button to edit the Transmitter Network Settings.

To change the IP address settings for a transmitter, the Administrator can enter the new IP address, subnet mask, and gateway, and then click on the Apply button.

The screenshot shows a web interface for configuring transmitter network settings. At the top, the title is "Transmitter Settings". Below the title, there is a field for "Transmitter IP Address" containing the value "192.168.1.22" and an "Apply" button to its right. A section titled "TX Network Settings" is enclosed in a light gray border. Inside this section, a message states "The Transmitter IP Address must be Static". Below this message are three input fields: "TX New IP Address" (192.168.1.22), "TX New Network Mask" (255.255.255.0), and "TX New Default Gateway" (192.168.1.1). There is also a checkbox labeled "TX LACP (active mode)" which is currently unchecked. At the bottom of the "TX Network Settings" section are two buttons: "Back" and "Apply".

FIGURE 8-29. TRANSMITTER NETWORK SETTINGS WINDOW



## CHAPTER 8: OSD FUNCTIONS

### Network Settings for 4K Transmitters

Emerald® 4K transmitters have additional network setting options that are not shown in Figure 8-29, including a field for setting the multicast IP address.

The Administrator can also select the port speed for the 4K transmitters. Options are “Auto,” “1G,” and “10G,” depending on the specification of the module being used.

The auto setting will automatically detect the maximum speed of the inserted module.

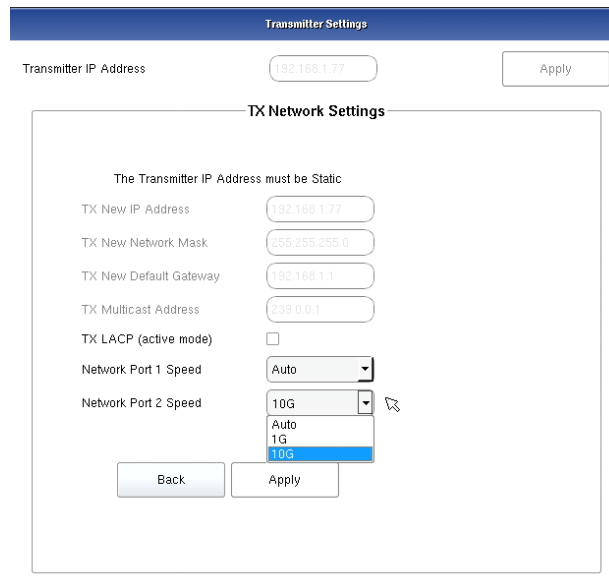

The screenshot shows the 'Transmitter Settings' window. At the top, there is a 'Transmitter IP Address' field with the value '192.168.1.77' and an 'Apply' button. Below this is the 'TX Network Settings' section, which contains a message: 'The Transmitter IP Address must be Static'. The settings include: 'TX New IP Address' (192.168.1.77), 'TX New Network Mask' (255.255.255.0), 'TX New Default Gateway' (192.168.1.1), 'TX Multicast Address' (239.0.0.1), 'TX LACP (active mode)' (checkbox), 'Network Port 1 Speed' (Auto), and 'Network Port 2 Speed' (10G). A dropdown menu for 'Network Port 2 Speed' is open, showing options: Auto, 1G, and 10G. At the bottom, there are 'Back' and 'Apply' buttons.

FIGURE 8-30. 4K TRANSMITTER NETWORK SETTINGS WINDOW

### Emerald 4K Transmitter Preferences

Starting with firmware 7.0, Emerald 4K transmitters have an additional option related to how the video stream will be encoded when an “Optimized” connection type is requested from the transmitter.

The “Optimized Compression” setting allows you to choose between two options:

#### 1. “Scaled Optimized”

This option is supported by all Emerald receiver types. It applies scaling to the ingested video content regardless of the resolution that the source is running.

# CHAPTER 8: OSD FUNCTIONS

## 2. "Optimized"

This option is only supported by receiver types that support video resolutions larger than 1920 x 1200, such as Emerald® 4K, DESKVUE, and RemoteApp.

NOTE: 2K Emerald receivers will display an error message if attempting to connect to a non-scaled 4K stream.

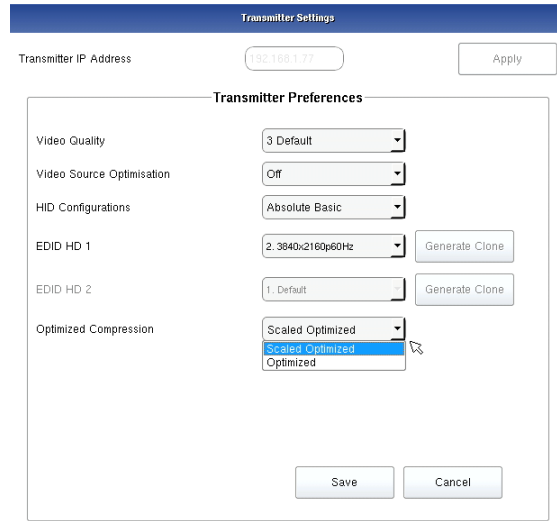

FIGURE 8-31. 4K TRANSMITTER PREFERENCES WINDOW



## CHAPTER 8: OSD FUNCTIONS

If the new IP address for the Emerald® transmitter is on a different subnet than the receiver, the receiver or Manager will not be able to communicate with it without going through a router. This is the case even on a point-to-point link between devices.

If the entered IP address is not the address of a valid Emerald transmitter or this address is unreachable, an error message is returned.

### Discover Transmitter IP Address

This requires the transmitter to be connected to the receiver on a point-to-point link or be the only transmitter on the attached network. In this case, the Administrator can click on the Discover button and follow the wizard to discover the IP address of the attached transmitter. This is required in the case when an Administrator does not know the transmitter's IP address.

### Transmitter Preferences

The Administrator can use the Transmitter Preference options to display the EDID stored on the KVM equipment and to change video quality settings, video optimization (for single-head systems only), and HID configuration. When the Transmitter Preferences button is clicked, the window shown in Figure 8-32 appears.

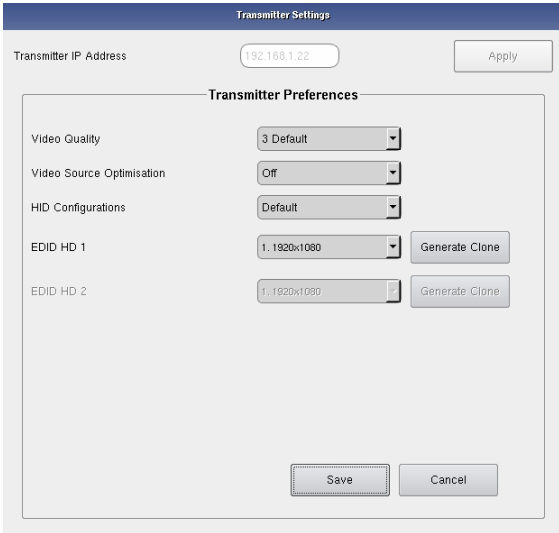

The screenshot shows a window titled "Transmitter Settings". At the top, there is a field for "Transmitter IP Address" with the value "192.168.1.22" and an "Apply" button. Below this is a section titled "Transmitter Preferences" containing several settings:

- Video Quality: 3 Default
- Video Source Optimisation: Off
- HID Configurations: Default
- EDID HD 1: 1. 1920x1080 (with a "Generate Clone" button)
- EDID HD 2: 1. 1920x1080 (with a "Generate Clone" button)

At the bottom of the window are "Save" and "Cancel" buttons.

FIGURE 8-32. TRANSMITTER PREFERENCES

## CHAPTER 8: OSD FUNCTIONS

### Transmitter Diagnostics

The transmitter provides diagnostics information for Black Box to debug customer encountered issues. When this button is clicked the user is asked to save the diagnostics onto a memory stick in the receiver unit. Send this file to Black Box for analysis. If the transmitter is in a system managed by Boxilla, the log files can be retrieved through the Boxilla dashboard under Devices --> Manage.

### Transmitter Video Quality Settings

The transmitter uses a progressive compression algorithm with 5 stages to reduce the bandwidth and increase the frame rate while sacrificing quality. At stage 5, which uses the best compression, you may achieve a higher frame rate and lower bandwidth, but the video output may show blocks of pixilation or screen artifacts as those parts of the screen are not being repainted because they didn't update. At the highest setting of stage 1, which is best quality, you will not see these screen artifacts as much, but you will be using a higher bandwidth with reduced frames potentially based upon your application. Frames are not always reduced; it just depends on the source and network.

Options:

1. Best Quality – lossless compression, pixel-perfect mode of operation. Generally needs dedicated network to ensure no frame loss.
2. Visually Lossless Compression – high-quality, visual image. Some compression on stream to reduce bandwidth to allow operation on standard corporate networks. Compression does not vary based on available network bandwidth, so may lead to some dropped frames during network congestion periods.
3. Optimized Quality (default) – system tuned to maintain visually lossless compression while increasing compression level during periods of network congestion to reduce frame loss. This balances visual quality with frame loss in periods of congestion, such as attempts to reduce/eliminate frame loss.
4. Optimized Bandwidth – system tuned to maintain visually lossless compression but increased levels of compression level during periods of network congestion to reduce frame loss. Optimized towards lower bandwidth during congestion periods compared to level 3.
5. Lowest Bandwidth – high level of compression to minimize average network bandwidth. No dynamic change to compression levels – always seeking to reduce bandwidth.

If the active IP address is not the address of a valid Emerald® transmitter or this address is unreachable, an error message is returned.



## CHAPTER 8: OSD FUNCTIONS

### Video Source Optimization (Applies to Single-Head Transmitters Only)

This is a progressive algorithm which helps to reduce unwanted noise coming from a GPU or video converters. The transmitter can be configured to handle different applications by changing the way it handles the video signal if it natively has embedded noise, such as from a VGA to DVI converter). You can choose to use DVI optimized, VGA high performance, VGA optimized, or VGA low bandwidth settings. You may change these options to get the best performance out of the transmitter. When the option is OFF, no dithering/noise techniques are enabled. DVI optimized, which is the least aggressive technique, uses a digital anti-dithering/anti-noise technique to reduce the extra noise which will allow the transmitter to operate at a normal pace and have better network performance. High performance is best used when there is an analog-to-digital video converter between the GPU and transmitter. It uses a low level technique. VGA optimized is best used when there is an analog-to-digital video converter between the GPU and transmitter. It uses a medium level technique. VGA low bandwidth is best used when there is an analog-to-digital video converter between the GPU and transmitter. It uses a high level technique. This would be considered the most aggressive technique to handle video dithering/noise.

NOTE: VGA Optimization is only supported on single-head transmitters; the dual-head transmitters and Emerald 4K do not support it. The dual-head Emerald SE/PE may not be the best option for sources that use Video Dithering technology.

### HID Configurations

This setting applies to all transmitters. It changes the USB communication between the Emerald transmitter and the target computer/device. Default will pass all available signals including audio, USB-R, USB HID as well as keyboard and mouse connections. Basic will pass USB HID only. It provides compatibility with DKM, DCX and older servers that require a keyboard and mouse HID only. Basic HID is also required to access any computer's BIOS menus. MAC supports MacOS® users. Absolute will be used with Windows®/Linux when RemoteApp or Freedom are being used in the setup. For normal usage, where mouse is directly connected to the receiver, then the Default or Basic options should be used. Absolute MAC will be used with MacOS® when used with Remote App or Freedom. Absolute Basic allows you to set the mouse to absolute while disabling the emulated audio device. This setting will typically be used where you wish to use the remote app and integrate the Emerald system with DKM and other systems that may be disrupted with audio enabled.

Absolute, Absolute MAC, and Absolute Basic can be used when the RemoteApp, DESKVUE, or Freedom II are used to enable the mouse.

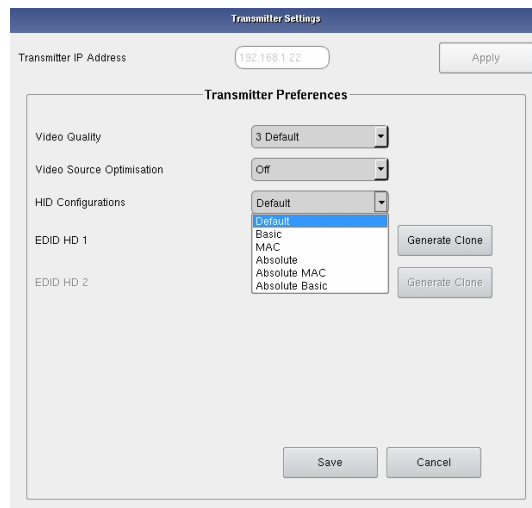

FIGURE 8-33. HID CONFIGURATION OSD OPTIONS

# CHAPTER 8: OSD FUNCTIONS

## EDID Settings

The transmitter can support native EDID options such as 1920x1080, 1920x1200, 1680x1050, 1280x1024, 1024x768, or you can choose to use the remote monitor EDID by clicking on the Generate Clone button, which will copy the desired video resolution to display at the receiver. The new EDID option will be added to the drop-down list, and it must be selected and saved before it is applied. This information is then shared with the computer's GPU so it sends the correct resolution and refresh rate. The Clone EDID 2 option applies to all dual-head transmitters and allows the Administrator to choose the desired video resolution to display at the receiver's second output.

NOTE: The computer may need to be restarted in order for the settings to work. If you find that changing the EDID settings makes the remote monitor blank out, you may need to select a different option to make it work. Once the Generate Clone EDID process is finished, it needs to be selected in the drop-down list and is not automatically applied until then.

## 8.7 USB DEVICES

The administrator can view and manage the attached USB devices that are connected to the receiver. If logged in as a user, this option will not be visible. The attached USB devices will be detected and displayed within the window, allowing the administrator to view and configure each device.

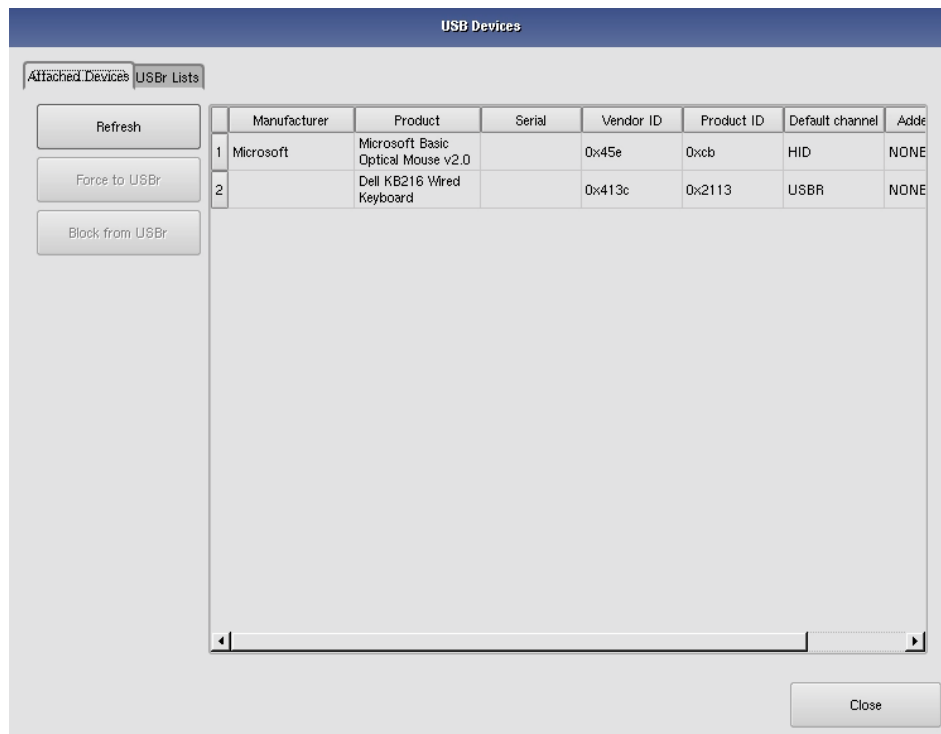

FIGURE 8-34. USB DEVICES



## CHAPTER 8: OSD FUNCTIONS

Each USB device will be interrogated, and the table will display details, including the Manufacturer, Product Type, Serial Number (if applicable), Vendor ID (VID), Product ID (PID), Default channel (current configuration), and List status.

Click on any device in the list and use the following configurations by clicking on the button.

**Refresh:** Refresh the list of devices when new devices are added or are not displaying in the menu.

**Force to USB:** Forcing a USB device down the USB channel will allow it to have full functionality, but any hotkey functionality will not be supported on it, if applicable.

**Block from USB:** Using this option will force the USB device down the USB HID channel. This will limit any features on transparent USB devices. This setting is more appropriate for keyboards and mice.

Clicking the USB Lists tab will show a new USB menu.

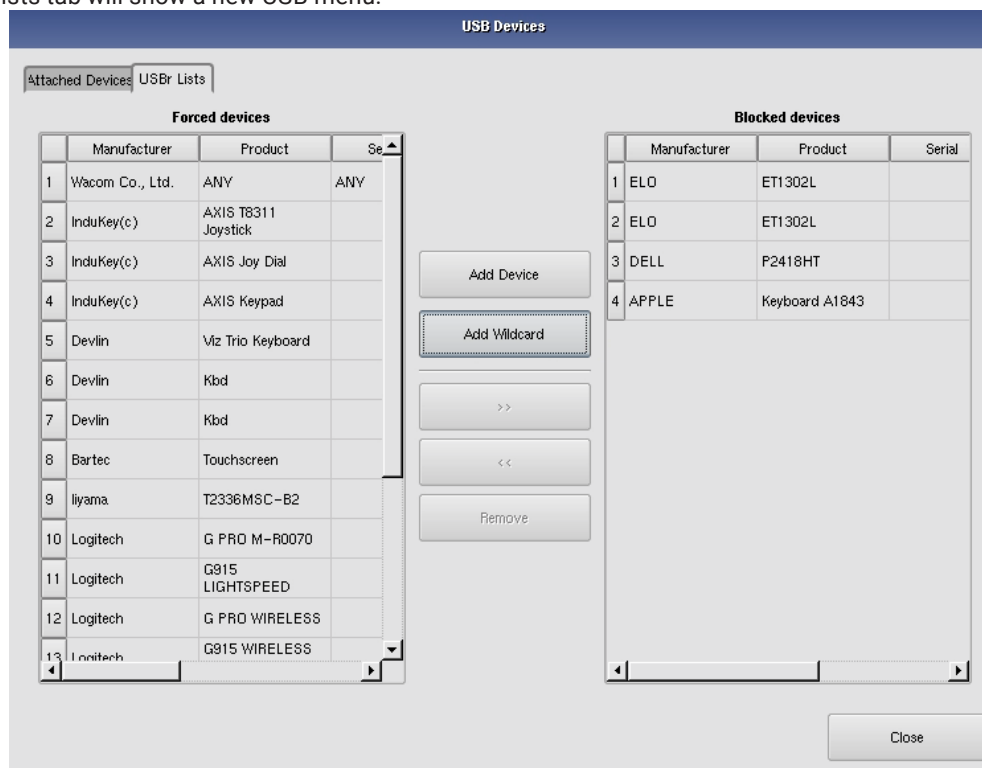

FIGURE 8-35. USB MENU

## CHAPTER 8: OSD FUNCTIONS

### Add Device

This tab will allow the administrator to add and manage which devices fall into which category. Clicking on the “Add Device” button will display a new menu which allows the entry of a new USB device.



FIGURE 8-36. USB DEVICE ENTRY SCREEN

This window will allow the administrator to key in a new USB device by adding the VID, PID, Vendor Name, Product Name, and then the option for USBt. Once a new item has been entered, click on the OK button to process it or click on the Cancel button to back out.

### Add Wildcard

This option allows for the entry of a wildcard USB device with less information than is required for the Add Device option.



FIGURE 8-37. ADD WILDCARD SCREEN

## 8.8 MANAGING USERS

Users are defined in the Emerald® system to provide rights to manage the system, rights to connect to different target devices and set parameters for connections. There are three types of users that can be created in an Emerald system.

1. Administrator – users of the class have full rights to configure the system, such as creating/modifying/deleting new users and connections, and changing network settings.
2. Power User – users of this class can modify resolutions for connections to virtual desktops and change his/her local password.
3. Standard Users – users of this class can only select from a list of pre-defined connections to access and view system information. They cannot change any configuration settings.

The Emerald receiver has one default user – admin, which is a member of the Administrator group. This user is defined by default and cannot be deleted. An Emerald receiver can have a maximum of 32 users defined.



# CHAPTER 8: OSD FUNCTIONS

To manage users, an Administrator selects the Users tab. This tab is only visible to Administrator class users.

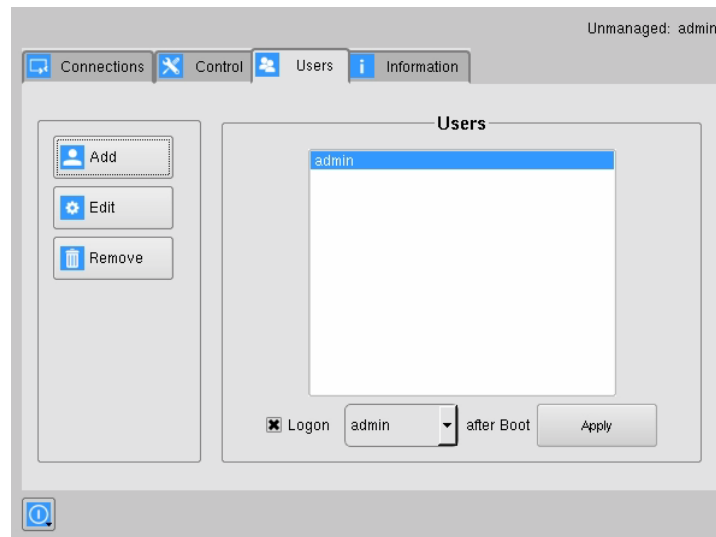

FIGURE 8-38. USER SCREENS

## 8.8.1 ADD A USER

To add a user, click on the Add button. This causes the New-User window to be displayed.

## 8.8.2 AUTO LOG ON

When the Log-on button is selected and a user is chosen, this user will be automatically logged on after power is applied to unit or after a reboot.

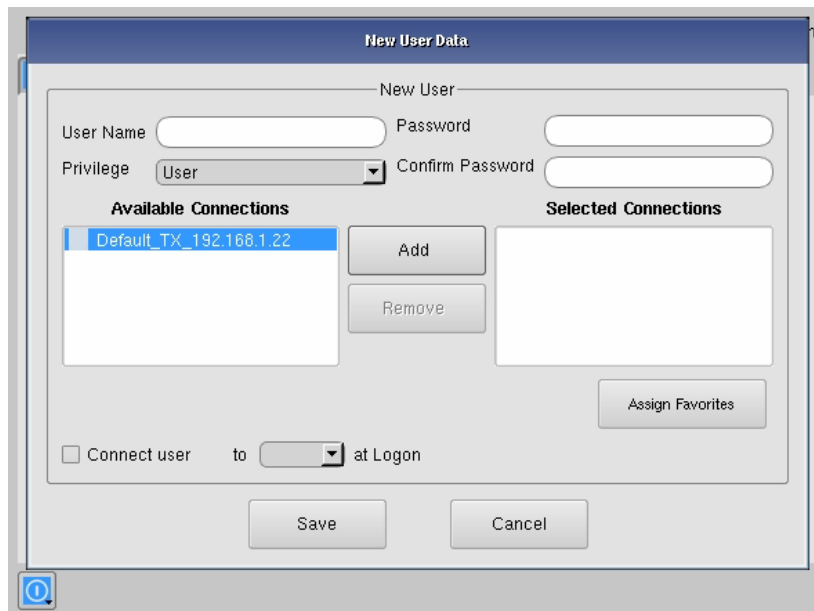

FIGURE 8-39. NEW USER WINDOW

## CHAPTER 8: OSD FUNCTIONS

When adding a new user, the following fields are used to define the user:

- ♦ **User Name:** This is a unique name that uses 1–32 characters. The username can be any valid username for a Microsoft O/S. This means the username MAY NOT contain “/ \ [ ] ; | = , + \* ? < > `”.
- ♦ **Password:** This field can be a minimum of 0 characters (i.e. blank) and a maximum of 32 characters. The password can be any valid password for a Microsoft O/S. The user password MAY contain the following special characters , ~ : ! @ # \$ % ^ & ' { } which means the password cannot contain “/ \ [ ] ; | = , + \* ? < > `”
- ♦ **Confirm Password:** This field must match the Password field. If there is a mismatch, a message is presented to the user in a pop-up screen.
- ♦ **Privilege:** This field, which is a drop-down list, defines the type of user the new user will be—Administrator or User.
- ♦ **Selected Connections:** The new user must be allocated connections that he/she can access. These are selected from the Available Connections window by the user selecting a set of connections (click on the connection in the Available Connection window and then click on the “Add” button). This causes the selected connections to be “added” to a user’s selected connection window.
- ♦ **Connect to at login:** This tick box defines whether the Emerald® receiver or Manager attempts to connect immediately to the selected connection after a logon by the user. This automatic connection only occurs after a logon. If a user exits the connection, the connection tab is displayed to the user for selection of a connection. This Connect to at Login is only saved when the Save button is clicked. If not clicked and another tab is selected, the changes are ignored. If not ticked, no automatic connection is made on log-in.

Once the new user fields have been filled out, the Save button must be clicked to create the new user. Clicking on the Save button causes the validation of the new username, checking that it is unique and that the two password entries match. If this validation fails, a pop-up window displays the reason for the failure – and the new user is not created. After dismissing the pop-up window, the user can fix the error and click on the Save button again.

Click on the Cancel button if the new user should not to be created.

### 8.8.3 EDIT A USER

To edit a user, click on the Edit button. This causes the Edit User Data window to be displayed.

The screenshot shows the 'Edit User Data' dialog box. The 'User Name' field contains 'User'. The 'Privilege' dropdown is set to 'User'. A 'Password Reset' button is visible. The 'Available Connections' list contains 'Default\_TX\_192.168.1.22'. The 'Selected Connections' list also contains 'Default\_TX\_192.168.1.22'. There are 'Add' and 'Remove' buttons between the lists. An 'Assign Favorites' button is at the bottom right. At the bottom, there is a checkbox for 'Connect user' (unchecked), a dropdown for 'User to' (set to 'Default\_TX\_192.168.1.2'), and the text 'at Logon'. 'Save' and 'Cancel' buttons are at the bottom center.

FIGURE 8-40. EDIT USER WINDOW



## CHAPTER 8: OSD FUNCTIONS

This window allows the user privilege type, the permitted connections available, the password, and the auto-connect option to be changed.

The default admin account gets access to all connections; this list cannot be modified. Other Administrator-type users can have their connection list modified.

Once the changes have been made for a user, they only become active once the Save button has been clicked. The changes can be abandoned by clicking on the Cancel button.

### 8.8.4 REMOVE A USER

To remove a user, highlight the user's name and then click on the Remove button.

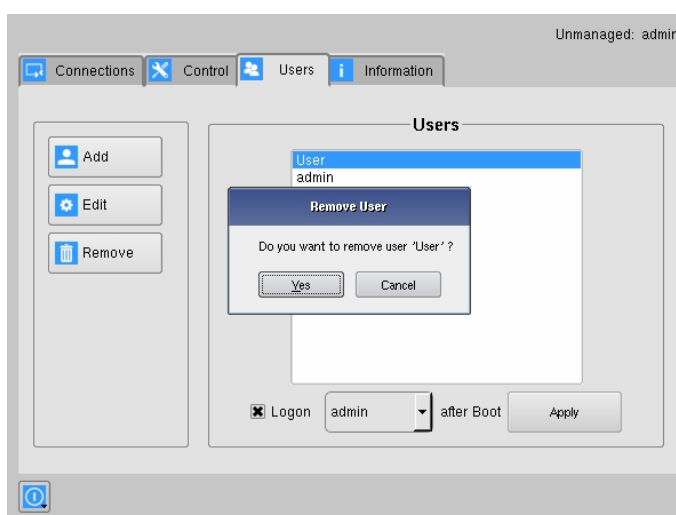

FIGURE 8-41. REMOVE USER

When the Remove button is clicked, a pop-up window is displayed to prompt confirmation that this user is to be deleted. Click on the Yes button to remove the user. Clicking on the No button causes this action to be aborted, and the user is not removed.

NOTE: There must always be a user of the name admin in the Emerald® system so the system can always be administrated. When attempting to remove the user, the system checks if the username is admin before it will allow the user to be removed.

## CHAPTER 8: OSD FUNCTIONS

### Information Tab

The information tab lets any user see the receiver's MPN (Manufacturers Part Number), Model, Serial Number, MAC Address, and Firmware version. This page also shows the IP Address, Network Mask, Gateway, Primary DNS, Secondary DNS, and Manager IP, where applicable. There are no user interactions on this page and it is used for informational purposes only.

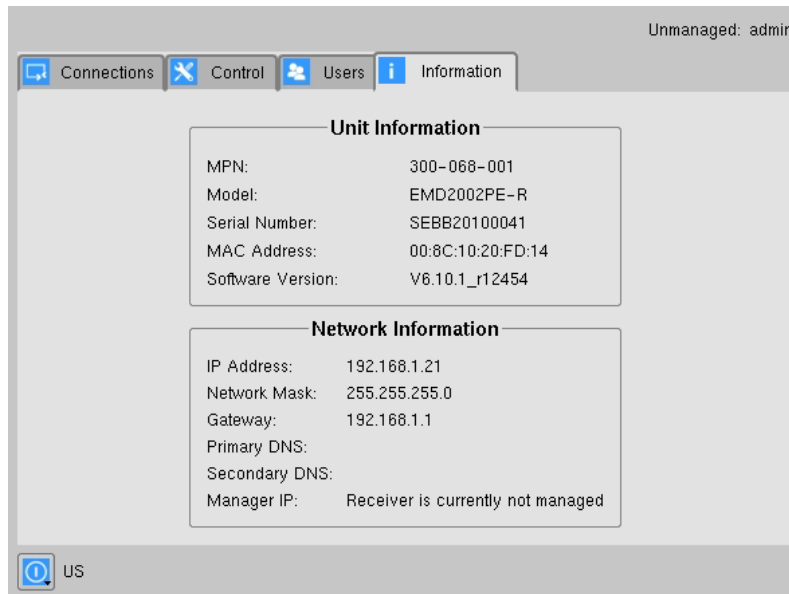

FIGURE 8-42. INFORMATION TAB

## 8.9 LACP

NOTE: LACP requires the Boxilla® manager.

To find out more information about the status of the Emerald® network interface(s), the Boxilla administrator can navigate to Devices>>Settings, and click on the LACP info panel. This will give a summary of the status of each Emerald NIC interface. Some of the information that can be found on this page is:

Active: Is the Ethernet port currently active

- ♦ Status: If the link is up or down
- ♦ Link Speed: The negotiated speed of the NIC
- ♦ Media: The type of network cable being used
- ♦ LACP: If the data is using LACP traffic

The Emerald LACP features do not support aggregation of the network ports to support two active ports. Only one network port is active at the same time, and both network ports will use the same IP settings. This protocol enables a network device to automatically bundle links by sending LACP packets to a directly-connected device that also uses LACP.



## APPENDIX A: EMERALD VIDEO RESOLUTIONS SUPPORTED

Emerald® 2K supports the resolutions listed below:

- ◆ 640 x 480 @ 60 Hz
- ◆ 640 x 480 @ 75 Hz
- ◆ 800 x 600 @ 60 Hz
- ◆ 800 x 600 @ 70 Hz
- ◆ 800 x 600 @ 72 Hz
- ◆ 800 x 600 @ 75 Hz
- ◆ 800 x 600 @ 85 Hz
- ◆ 1024 x 768 @ 60 Hz
- ◆ 1024 x 768 @ 75 Hz
- ◆ 1024 x 768 @ 85 Hz
- ◆ 1280 x 800 @ 60 Hz
- ◆ 1280 x 960 @ 60 Hz
- ◆ 1280 x 960 @ 85 Hz
- ◆ 1280 x 1024 @ 60 Hz
- ◆ 1280 x 1024 @ 75 Hz
- ◆ 1280 x 1024 @ 85 Hz
- ◆ 1366 x 768 @ 60 Hz
- ◆ 1400 x 1050 @ 60 Hz
- ◆ 1440 x 900 @ 60 Hz
- ◆ 1600 x 900 @ 60 Hz
- ◆ 1680 x 1050 @ 60 Hz
- ◆ 1600 x 1200 @ 60 Hz
- ◆ 1680 x 1050 @ 60 Hz
- ◆ 1280 x 720 @ 60 Hz
- ◆ 1920 x 1080 @ 60Hz
- ◆ 1920 x 1200 @ 60 Hz

Emerald 4K supports the resolutions above and the resolutions listed below:

- ◆ 3840 x 2160 @ 30 Hz
- ◆ 4096 x 2160 @ 60 Hz
- ◆ 3440 x 1440 @ 60 Hz

Emerald also will pass all the above resolutions at refresh frequencies from 15 Hz to 60 Hz. Those with non-defined VESA resolutions will be displayed at 60 Hz even if the incoming resolution is not 60 Hz.

Emerald 4K lossless codec connections can also potentially support higher refresh rates for lower video resolutions. Contact Black Box support to verify support for your specific application.



# APPENDIX B: EMERALD 4K MODELS

## B.1 COMPATIBLE RACKMOUNT KITS

COMPATIBLE RACKMOUNT KITS		
PART NUMBER	RACKMOUNT KIT(S)	NOTE
EMD200DV-T EMD200DP-T	N/A	Not required
EMD2000SE-T EMD2002SE-T EMD2000SE-R EMD2002SE-R	(1) DTX1000-RMK1 (2) DTX1000-RMK2 (1) EMD2000-RMK2	*EMD2000-RMK2 contains only 1 SE bracket, so only 1 SE can be mounted
EMD2000PE-T (-P) EMD2002PE-T (-P) EMD2000PE-R (-P) EMD2002PE-R (-P)	(2) EMD2000-RMK2	
EMD2000PE-DP-T EMD2002PE-DP-T	(3) EMD2000-RMK3	
EMD2000PE-DP-R EMD2002PE-DP-R	(2) EMD2000-RMK2	
EMD2000SE-DP-T EMD2002SE-DP-T	(3) EMD2000-RMK3	
EMD2000SE-DP-R EMD2002SE-DP-R	(3) EMD2000-RMK3 (2) EMD2000-RMK2	
EMD2000SE-T-R2 EMD2000PE-T-R2 EMD2002PE-T-R2	(3) EMD2000-RMK3 (2) EMD2000-RMK2	
EMD4000T EMD4000R	(2) EMD4000-RMK1 (2) EMD4000-RMK2-SLIM	

## B.2 COMPATIBLE NETWORK SWITCHES

The following network switches have been validated and are recommended when using Emerald® 4K transmitters and receivers:

COMPATIBLE NETWORK SWITCHES	
PART NUMBER	DESCRIPTION
EMS10G12	12-Port, 10Gbps SFP+ (unpopulated) Network Switch
EMS10G28	28-Port, 10Gbps SFP+ (unpopulated) Network Switch
EMS100G32-R2	32-Port, 100Gbps (unpopulated) Network Switch



# APPENDIX B: EMERALD 4K MODELS

## B.3 COMPARISON CHART

SPECIFICATION COMPARISON CHART: TRANSMITTERS AND RECEIVERS							
	NUMBER OF VIDEO HEADS	USB PORTS	NETWORK	SERIAL	AUDIO	SFP	RESOLUTION
<b>RECEIVERS</b>							
4K RECEIVER (EMD4000R)	(1) DISPLAYPORT	(4) USB TYPE A	(2) SFP+	(1) DB9	(2) 3.5-MM	(2)	4096 x 2160
<b>TRANSMITTERS</b>							
4K TRANSMITTER (EMD4000T)	(1) DISPLAYPORT	(1) USB TYPE B	(2) SFP+	(1) DB9	(2) 3.5-MM	(2)	4096 x 2160

## B.4 COMPATIBLE SFPS

COMPATIBLE SFPS	
PART NUMBER	DESCRIPTION
LFP441	SFP 1000BASE-SX 850NM Multimode LC
LFP442	SFP 1000BASE-LX 1310NM Singlemode LC
LSP421	SFP+ - 10-Gb, Extended Diagnostics, 850-nm Multimode Fiber, 300-m, LC
LSP422	SFP+, 10GBASE-R, 1310-nm single-mode, 10 km
LSP443	SFP+, 10GBASE-T, RJ-45
LSP441	SFP+ - 10-Gb, Extended Diagnostics, 850-nm Multimode Fiber, LC
LSP442	SFP+ - 10-Gb, Extended Diagnostics, 1310-nm Single-mode Fiber, LC

**NOTE:** When picking an SFP+ above, verify you get a matching SFP for proper communication (for example, one SFP is on the unit, and the other SFP is on the network switch).

## B.5 COMPATIBLE CABLES

The following Active Optical Cables and Direct Attach Cables are available for use with the Emerald 4K (EMD4000T, EMD4000R). They can be used instead of SFP+, and these are an all-in-one interconnect cable.

COMPATIBLE 10G DIRECT ATTACH CABLES FOR NETWORKING	
PRODUCT CODE	LENGTH
<b>SFP-H10GB-CU50CM-BB</b>	50-cm
<b>SFP-H10GB-CU1M-BB</b>	1-m
<b>SFP-H10GB-CU1M5-BB</b>	1.5-m
<b>SFP-H10GB-CU2M-BB</b>	2-m
<b>SFP-H10GB-CU3M-BB</b>	3-m
<b>SFP-H10GB-CU5M-BB</b>	5-m



# APPENDIX B: EMERALD 4K MODELS

## B.6 GUIDELINES FOR SYSTEM HARDENING FOR AN EMERALD DEPLOYMENT

Below is a checklist for hardening an Emerald system deployment:

### 1. Check Physical Deployment and Connections

---

1.1. Verify all Receivers and Transmitters are secure in place and labeled to customer requirements (e.g. include IP address label on a unit).

1.2. Verify that devices are securely mounted/installed.

1.3. Verify that physical access to devices meet deployment requirements – locked rooms, Kensington lock.

1.4. Verify that cables are of sufficient quality and connected securely.

1.5. Use cable ties or conduits to secure cables.

1.6. Verify that all Receivers and Transmitters have a valid/active network connection and required IP address:

1.6.1. Verify that all units have active connections on each network port.

1.6.1.1. Verify the LED on units.

1.6.1.2. Ping the IP address of unit – can be from Boxilla®.

1.6.1.3. Verify the list of devices have correct IP addresses from Boxilla.

1.6.1.4. Select a device from Boxilla and verify if the correct device LED is set on the device.

1.7. Verify that devices with redundant network connections have each connection working correctly:

1.7.1. Verify that the primary port is functional by selecting the device from Boxilla and verifying that Device LED is shown.

1.7.2. Disconnect an active network port and verify that “backup/redundant” port becomes active:

1.7.2.1. Verify that network ports LEDs become “active” on the new port – note “failover time.”

1.7.2.2. Select a device from Boxilla and verify if the correct device LED is set on the device.

1.8. Recommendations for device installation/positions:

Component	Hardening Measure
TX Units	Mount in locked 19” racks with rack intrusion sensors.
RX Units	Deploy in secure client rooms with CAC/PIV authentication.
Network Links	Use armoured fibre between core switches and TX/RX clusters.

### 2. Check User Access Rights

---

2.1. Verify Administrators defined in Boxilla, as required.



## APPENDIX B: EMERALD 4K MODELS

- 2.2. Verify that Active Directory is configured (including redundant AD controllers) correctly – ping AD controller from Boxilla® to validate access.
- 2.3. Verify only local KVM users defined as required by deployment – remove any users added for commissioning.
- 2.4. Map KVM groups to AD groups to enable “group” mapping of connections, if required by deployments.
- 2.5. Implement strong, unique passwords for the KVM switch and receiver’s administrative interfaces.
- 2.6. Use a combination of uppercase and lowercase letters, numbers, and symbols.
- 2.7. Establish a policy for regular password changes (e.g., every 30-90 days).
- 2.8. Enforce password complexity requirements.
- 2.9. Change or disable default administrator accounts and passwords immediately.

### 3. Network Segmentation

---

- 3.1. Verify that network switches and, subnets policy are defined.
- 3.2. Ideally place the KVM switch and receiver on a separate, secure network segment.
- 3.3. Verify the routing policy between subnets/VLANs.
- 3.4. Configure firewalls to restrict network access to the KVM switch and receiver.
- 3.5. Only allow necessary ports and protocols (check Emerald manuals for ports used by Emerald).
- 3.6. Multicast Traffic Optimization
  - 3.6.1. Enable IGMP/IGMP snooping on all switches to prevent multicast flooding if any EMD-4k is used on deployment. Recommend IGMPv3 is enabled on all switches to minimise risk of flood from any multicast traffic.
  - 3.6.2. Verify that avdedicated/unique multicast group is defined for each EMD-4k – use Boxilla for this.

### 4. Firmware Updates

---

- 4.1. Confirm Receivers, Transmitters and Network Switches have the defined firmware in each device – use Boxilla to check this.



## APPENDIX B: EMERALD 4K MODELS

### 5. Logging and Alert Updates

---

5.1. Configure syslog with appropriate levels of alerts and define where syslog should be sent (on Boxilla) – as required by deployment.

5.2. Configure SNMP with appropriate levels of alerts and define where SNMP traps should be sent on Boxilla) – as required by deployment.

5.3. Configure Email Alerts with appropriate levels of alerts and define where emails should be sent (on Boxilla) – as required by deployment.

5.4. Regularly review logs for suspicious activity.

### 6. Auto-Logout/Timeouts

---

6.1. Configure the receiver and any associated software to automatically log out after a period of inactivity as required by the deployment.

6.2. Set appropriate timeout values to minimize the risk of unauthorized access.

### 7. Disable Unnecessary Services

---

7.1. Disable any unnecessary services or features on the devices – for both receivers/transmitters and network switches.

7.2. Train users to log out of systems and the receiver when they are finished (and ensure time-outs to auto-log out are in place).

7.3. Emphasize the importance of not leaving systems unattended.

### 8. Secure Work Practices

---

8.1. Educate users about the risks of sharing login credentials or leaving sensitive information visible.

8.2. Educate users on the dangers of plugging in unsanctioned USB devices.

8.3. Only enable vUSB on connections that need it (to limit which USB 2.0 devices can be connected to the target computer. For better security, if only a keyboard and a mouse is required, disable the vUSB option on the connection so that USB flash drives and other devices cannot be used.)

8.4. Conduct regular physical inspections of the KVM switch, receiver, and cabling.



## APPENDIX B: EMERALD 4K MODELS

- 8.5. Check for any signs of tampering or damage.
- 8.6. Perform periodic security audits to assess the effectiveness of security measures.
- 8.7. Identify and address any vulnerabilities.

### 9. Tamper-Evident Configuration

---

- 9.1. Apply epoxy seals on Emerald unit reset buttons to detect physical access attempts – if required by deployment.
- 9.2. Store factory reset tools (paper clips) in controlled-access containers per NIST SP 800-116 guidelines.

### 10. Operational Best Practices

---

- 10.1. Performance Tuning: Reduce network traffic by Emerald video optimization:
  - 10.1.1. For VGA sources or Dithering sources – set Video Optimisation on associated Transmitters as per manual guidelines.
  - 10.1.2. Set compression levels for transmitters – from best quality to best compression – based on needs for that source. The default is sufficient for most deployments and sources.
- 10.2. Only enable vUSB devices when a non keyboard-mouse is needed for a connection (to minimize security risks).
- 10.3. Only enable audio on a connection where audio is needed.



## APPENDIX C: NETWORK REQUIREMENTS AND PORT USAGE

Emerald® transmitters and receivers will require specific network requirements to ensure high-quality video and low latency. The technology can utilize unicast and multicast packets, so having a good, properly configured network backbone is required. Unicast is a protocol designed to send network packets from a single transmitter to a single receiver (about 200 Mbps for 2K video and about 10 Gbps of bandwidth for 4K video). Multicast is a protocol designed to send network packets from a single transmitter to more than 1 receiver, but the method of sending this data is extremely efficient.

In Unicast mode, every receiver will use up to around 200 Mbps for 2K video and around 10 Gbps for 4K video. This means that with four receivers, you are sending 200 Mbps for  $2K \times 4 = 800$  Mbps, and  $10 \text{ Gbps} \times 4 = 40$  Gbps from the transmitter.

When using Emerald 4K devices (EMD4000T, EMD4000R) in Multicast mode, every receiver can get up to 10 Gbps of data. However, the transmitter will send the data once via Multicast, and the network switch will then determine who is part of the IGMP group and properly distribute that data to those selected receivers (or passing through network switches if using more than one network switch). This is more network switch intensive, but allows for a lot of multimedia data to be transposed across a network of a single switch or multiple switches.

Using Multicasting technology on a network switch that cannot handle it will result in the network switch taking in the 10 Gbps from a transmitter and broadcasting it out to every port whether that device wants the info or not; therefore, selecting the proper network switch that can support Multicasting is extremely important to avoid network saturation or bringing the network down. The network switch that isn't capable of handling this Multicasting traffic will typically begin to make every status LED on the switch blink in synchrony, indicating something is wrong.

Emerald 2K and Emerald 4K devices can be on the same network if designed properly. The Emerald 2K devices can connect to 1 Gbps network switches and have an uplink/LACP connection to a 10 Gbps network switch, which would interface with the Emerald 4K devices directly. When using the proper connection codecs, an Emerald 2K receiver can connect to a 4K Transmitter when the connection mode is set to Optimized.

### C.1 RECOMMENDED NETWORK DESIGN

It is best practice to put transmitters on the same switch as the receivers who are accessing those most frequently to reduce overhead on the network switch trunks. Placing transmitters and receivers on different switches, however, is completely acceptable and it happens frequently; just validate that the switch uplink/LACP can handle all the bandwidth.

NOTE: Verify that you do not have any device using 192.168.1.1; otherwise Endpoint Discovery using Boxilla will not work.

### C.2 MULTI-SUBNET SUPPORT

Emerald 2K and Emerald 4K are capable of going over multi-subnets and the internet if properly configured and if the service line is capable of handling the bandwidth. To go from one subnet to another, you will need to utilize a Layer 3 switch to accommodate the connection (or you may want to consider using VLANs to separate corporate network with KVM network). If going over the internet, you must assign an external IP address to an internal one, and then configure the device to use the internal IP, or configure port forwarding on the router. The router will know how to handle it if properly configured. VPNs are often used, but not all are supported. For Emerald 4K, it is not recommended to use over the internet/VPN due to the amount of bandwidth it can consume; these applications typically have dedicated lines that can support high-bandwidth connections.

### C.3 4K MULTICAST SUPPORT

Emerald 4K will use Multicast IP traffic when at firmware version 1.4 or higher. If you connect more than one Emerald 4K transmitter to an unconfigured network, you will begin to have problems since all of the transmitters use the same default Multicast IP.



## APPENDIX C: NETWORK REQUIREMENTS AND PORT USAGE

Since these all need to be unique, follow these steps:

Unmanaged Transmitters:

1. In the OSD of the Emerald® 4K Receiver, go to Control-->Transmitter, type in the transmitter's IP address, and press okay. After a few moments, if the transmitter is online, several buttons are now available to click on.
3. Click on the Network button and configure the Multicast IP address to 239.0.0.5 and larger (for example, 239.0.0.5 TX1, 239.0.0.6 TX2, 239.0.0.7 TX3) using port 8001. Also be sure your network switch IGMP range covers this IP.
4. Apply your settings and close.

Managed Transmitters:

1. Go to Boxilla under Devices-->Settings.

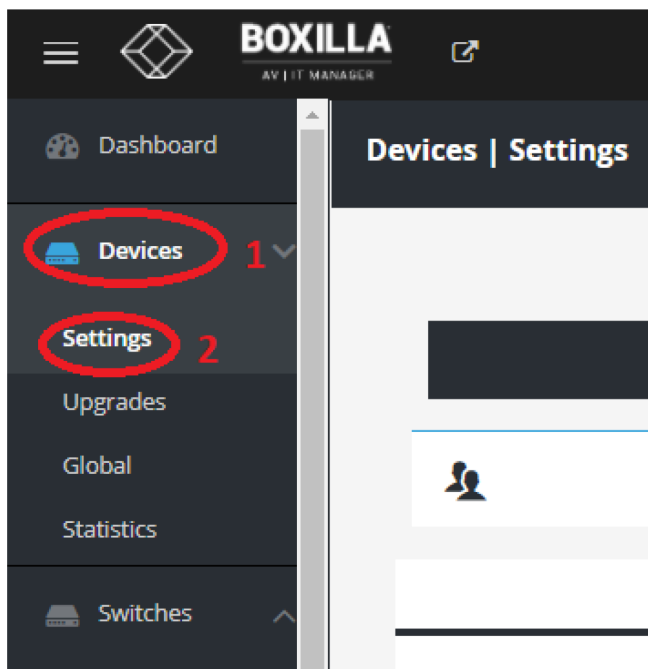

FIGURE C-1. SETTINGS SCREEN

# APPENDIX C: NETWORK REQUIREMENTS AND PORT USAGE

2. Find the Emerald 4K transmitter, click on the ellipsis, and go to Edit Network.

EMD2000PE-T (A)	-	Unique	10.0.0.215	EMD2000PE-T	OnLine	Configured	Best Quality	Off	1920x1080	-	-	-	-	-	-	-	-	-	-
EMD4000T (A)	1	-	Unique	10.0.0.220	EMD4000T	OnLine	Configured	-	-	Default	-	-	-	-	-	-	-	-	-
EMD4000R (A)	-	Unique	10.0.0.221	EMD4000R	OffLine	Configured	-	-	-	-	-	-	-	-	-	-	-	-	-
EMD4000R (B)	-	Unique	10.0.0.222	EMD4000R	OffLine	Configured	-	-	-	-	-	-	-	-	-	-	-	-	-
EMD2000PE-R (A)	-	Unique	10.0.0.211	EMD2000PE-R	OffLine	Configured	-	-	-	-	-	-	-	-	-	-	-	-	-
EMD2002PE-R (A)	-	Unique	10.0.0.210	EMD2002PE-R	OffLine	Configured	-	-	-	-	-	-	-	-	-	-	-	-	-
DTX1000SA-R (A)	-	Unique	10.0.0.213	DTX1000SA-R	OffLine	Configured	-	-	-	-	-	-	-	-	-	-	-	-	-
EMD2002SE-R RX1	-	Unique	10.0.0.212	EMD2002SE-R	OnLine	Configured	-	-	-	-	-	-	-	-	-	-	-	-	-

FIGURE C-2. EDIT NETWORK OPTION

3. Verify that Multicast Master Port is set to 8001, and verify that each Emerald 4K transmitter's Multicast IP has a unique value starting at 239.0.0.2. Once done, press apply. Do this for every transmitter and verify that the Multicast IP is unique.

NOTE: On your network switch with IGMP Snooping is enabled for Multicasting Traffic, verify that your Multicasting IP scope is well within limits for the Emerald 4K transmitter range 239.0.0.x.

Model EMD4000T  
MAC 1C:37:BF:00:11:70  
IP Address 10.0.0.220  
Gateway 10.0.0.1  
Netmask 255.255.0.0  
Primary DNS  
Secondary DNS  
Multicast IP 239.0.0.5  
Multicast Master Port 8001  
State OnLine  
Cancel Apply

FIGURE C-3. MULTICAST IP SETTING



# APPENDIX C: NETWORK REQUIREMENTS AND PORT USAGE

## C.4 TCP/UDP PORT USAGE

TCP/UDP PORT USAGE				
	APPLICATION	PORT	EMERALD 4K	EMERALD SE/PE/ZU
APPLIANCE	Appliance REST HTTP	TCP: 7778	Yes	Yes
	Appliance REST HTTPS	TCP: 8888	Yes	Yes
	Stats Gathering Internal Port	TCP: 9998 (internal use only; might show on scan)	Yes	Yes
	Communications	TCP: 22	Yes	Yes
	Manager Discovery (to Appliance): Multicast 224.0.1.249. Appliance Listens on UDP Port	UDP: 39150	Yes	Yes
	(4K Only) Default Slave Multicast IP Port (IP: 239.0.0.1)	UDP: 8000	Yes	No
	(4K only) Default Master Multicast IP Port (IP: 239.0.0.1)	UDP: 8001	Yes	No
	Audio (Private/Multi Unicast)	TCP: 9000	Yes (1.2 onwards)	Yes (5.0.x onwards)
	Video EMDSE & 4K	TCP: 16384	Yes	Yes (5.3.x onwards)
	Video, 2nd channel, (Paired only)	TCP: 16385	No	Yes (5.4.x only)
	Reserved – Future	TCP: 16387		
	Reserved – Future	TCP: 16388		
	Multicast 225.0.0.37 (Appliance – recovery)	UDP: 12345	Yes	Yes
	RDP VM & RDP Broker	TCP: 3389 (default)	Yes (Default)	Yes (Default)
	Horizon Client	TBD		
Transmitter Connections	TCP: 3389	Yes	Yes	
BOXILLA	Boxilla REST HTTPS	TCP: 443		
	Boxilla Smart Proxy HTTP	TCP: 8000 (Boxilla internal only)		
	Communications	TCP: 22		
	Discovery: Multicast 224.0.1.249 (Send)	UDP: 39150		

RemoteApp requires TCP/UDP Port 443, 3389, and 16384 to be open.

NOTE: Firewalls on the WAN may cause audio to fail due to a protocol issue that prevents it traversing some firewalls. The audio channel does not perform the SYN/SYNACK sequence which leads to some of these streams being blocked.



# APPENDIX C: NETWORK REQUIREMENTS AND PORT USAGE

## C.5 NETWORK SWITCH REQUIREMENTS

NETWORK SWITCH REQUIREMENTS		
WHEN REQUIRED	SWITCH SETTING	DESCRIPTION
<b>4K only</b>	IGMP Capable	Must support IGMP V1, V2, or V3
<b>4K only</b>	10 Gig Ports	Each port on the switch needs to support 10 G for best operation. Emerald® 4K units, however, can now also support 1G connectivity from firmware 7.0 onward.
<b>2K and 4K</b>	Backplane Support	If you have a 1Gbps 28-Port switch, the backplane should be capable of handling 28 Gbps or more. Some switches will have 28 ports but the backplane supports 24 Gbps or less. Be sure to calculate the bandwidth across the network to eliminate any bottlenecks.
<b>4K only</b>	Switch CPU	The network switch should have a heavy duty CPU that can handle the constant processing on the IGMP groups.
<b>Not required but recommended for 2K and 4K</b>	VLAN Configuration	It is advised to setup a VLAN for the Emerald® 2K and Emerald 4K system to keep it separate from other devices on the network. This is not required; it is a suggestion to keep things easy to manage. If using the EMS10G28, you are REQUIRED to make a secondary VLAN since you cannot configure Multicasting on the default VLAN1.
<b>Uplinks (2K and 4K)</b>	Switch Trunks / LACP	Review switch trunks and LACP configuration to verify that the link can handle the required bandwidth between switches.



## APPENDIX D. CONFIGURING WINDOWS 10 VIRTUAL MACHINES

A few properties must be configured on a target Windows® virtual machine for Emerald® to connect with it.

On the Windows virtual machine click on the Start button and launch a command window. Then launch group policy editor – gpedit.msc.

Start >> Run >> “cmd” >> “gpedit.msc”

Once the Local group Policy editor is open follow this path:

Computer Configuration >> Administrative Templates >> Windows Components >> Remote Desktop Services >> Remote Desktop Session Host >> Remote Session Environment

Ensure the following three policies are set as follows:

1. Optimize visual experience when using RemoteFX.

- ♦ For this policy set both the Screen Capture Rate and Screen Image Quality to Highest.

2. Configure RemoteFX.

- ♦ Set this policy to Enabled.

3. Limit maximum color depth.

- ♦ Set this policy to Client Compatible.

Once the above policies have been applied, reboot the virtual machine. It is now enabled for Emerald connections.

There are different settings to optimize the performance of Emerald with different Windows operating systems. These are defined in the application note – “Emerald Group Policies for Optimal Performance for Windows Targets.”

It is not possible to connect to a transmitter from a computer/laptop running RDP. A receiver is always required.



## APPENDIX E. EMERALD NETWORK PROTOCOLS OVERVIEW

Emerald® uses standard IP protocols for communication between receivers and transmitters. Port 3389 is used for unicast communications.

For management purposes some other ports are used. The Black Box discovery protocol used UDP Multicast Group 224.0.1.249 (port 39150). This is sent by the Boxilla® Manager to discover Emerald devices in the network. The router must allow UDP Multicast forwarding to allow devices on subnet different to where Manager is located to be discovered.

Emerald devices respond to the discovery multicast by sending a UDP unicast back to Manager IP address on the same port (Port 39150).

Once an Emerald device is part of the managed domain, the Manager periodically audits the device to determine information such as if the device on-line, who is logged into devices, device statistics, etc. These audit requests and responses are unicast UDP to specific IP addresses (responses are sent back to Manager's IP address) on port 39150.

On power-up, a transmitter sends out a "here I am" multicast message on multicast group 225.0.0.37 on port 12345.

As part of management configuration, the Manager may communicate to a specific device on port 22 (TCP unicast communications).

Emerald can operate across multiple VLANs or subnets. Basic IP networking rules need to be followed; there should be a router in the network to enable the various devices on different subnets to communicate with each other.

To allow Black Box's Emerald discovery protocol to operate, Multicast routing should be enabled. Black Box's Emerald discovery protocol is not required for Emerald systems to operate, but it is recommended to enable an Emerald Manager to search for devices across the network. If the Emerald SE discovery protocol is not enabled, such as when the router does not have multicast routing enabled, the Administrator will have to manually add in all devices not on its subnet. For example, each device needs to be added individually by its IP address.



# APPENDIX F. TROUBLESHOOTING

This page covers some basic notes & troubleshooting when using the Emerald®.

Operating Modes: Connecting to an Emerald transmitter from an RDP client that is from a laptop/computer is not possible; you must use an Emerald receiver for this. An Emerald receiver can connect to an Emerald transmitter and RDP server.

**TABLE D-1. OPERATING MODES CONFIGURATIONS**

USER SIDE	COMPUTER SIDE	OPERATION
Laptop/Computer w/RDP Client	Emerald SE or PE Transmitter or Emerald ZeroU Transmitter	This is not supported and will not work.
Emerald SE Receiver	Emerald SE or PE Transmitter or Emerald ZeroU Transmitter	Fully supported
Emerald SE Receiver	RDP Server on VM or OS	Fully supported

Sluggish Mouse: When using the Emerald, you may find that the mouse is not being very responsive, or has a noticeable delay. This can typically occur if the video card is using dithering technology. You can contact Black Box to get a small utility to disable video card dithering on AMD graphics cards or use video optimization, which is set on the Transmitter -> Preferences page for single-head transmitters only.

Error Codes: The following error codes expanded.

1 GENERAL\_ERROR

Connection protocol failure. Are the unit(s) at the correct and compatible software version?

2 INIT\_FAIL

Can't start protocol. Is the receiver at the correct software version?

3 GET\_SOCKET

Protocol Start Failure. Are the unit(s) at the correct and compatible software version?

4 CREATE\_SESSION\_FAIL

Can't create session. Is the transmitter connected and powered on?

5 CONNECT\_FAIL

Can't create session. Is the transmitter connected and powered on? Is port 22 open between units?

6 TX\_CHECK\_FAIL

Target device is not a transmitter. Is the transmitter's IP address correct?

7 VER\_CHECK\_FAIL

Can't read device Version. Is the transmitter connected and powered on?

8 LED\_FLASH\_FAIL

Start LED Flash command failed on remote device. Is the transmitter connected and powered on?

9 FILE\_SEND\_FAIL

Can't send upgrade file to transmitter. Is the transmitter connected and powered on?

10 PERMISSION\_CHANGE\_FAIL

Update to change settings on transmitter. Is the transmitter connected and powered on?

11 EXTRACT\_UPGRADE\_FAIL

Failed to extract upgrade file. Is the upgrade file correct or damaged?



## APPENDIX F. TROUBLESHOOTING

### 12 RUN\_UPGRADE\_FAIL

Upgrade failed. Is the upgrade file correct or damaged?

### 13 REBOOT\_FAIL

Failed to reboot remote device unit. Is the remote device connected and powered on?

### 14 FILE\_SEARCH\_FAIL

Upgrade file format failed. Is the upgrade file correct or damaged?

### 15 LISTEN\_ERROR

Connection protocol failure. Are units at the correct and compatible software version? Is the transmitter connected and powered on?

### 16 SOCKET\_OPTION\_ERROR

Connection protocol failure. Are units at the correct and compatible software version? Is the transmitter connected and powered on?

### 17 SOCKET\_BIND\_ERROR

Connection protocol failure. Are units at the correct and compatible software version? Is the transmitter connected and powered on?

### 18 RECVFROM\_ERROR

Connection protocol failure. Are units at the correct and compatible software version? Is the transmitter connected and powered on?

### 19 GET\_INFO\_FAIL

Failed to retrieve Info tab from remote device. Are units at the correct and compatible software version? Is the transmitter connected and powered on?

### 20 COMPATIBILITY\_FAIL

Upgrade file is incompatible with version on unit. Please check release notes for correct version and compatibility information.

### 21 BRAND\_CHECK\_FAIL

This is not a correct upgrade file for Emerald®. Please check release notes for correct version and compatibility information.

### 22 CLASS\_CHECK\_FAIL

Can't upgrade transmitter with receiver file or visa versa. Please check release notes for correct version and compatibility information.

### 23 PACKAGE\_CHECK\_FAIL

Incorrect upgrade file for this model. Please check release notes for correct version and compatibility information.

### 24 NO\_UPGRADE\_REQUIRED

No upgrade required. This version of code is already on the device. No upgrade is required.



# APPENDIX G. REGULATORY INFORMATION

## G.1 FCC STATEMENT

This equipment has been tested and found to comply with the limits for a Class A digital device, pursuant to part 15 of the FCC Rules. These limits are designed to provide reasonable protection against harmful interference when the equipment is operated in a commercial environment. This equipment generates, uses, and can radiate radio frequency energy and, if not installed and used in accordance with the instruction manual, may cause harmful interference to radio communications. Operation of this equipment in a residential area is likely to cause harmful interference in which case the user will be required to correct the interference at his own expense.

This Class A digital apparatus complies with Canadian ICES-003.

Cet appareil numérique de la Classe A est conforme à la norme NMB-003 du Canada



## APPENDIX G. REGULATORY INFORMATION

### G.2 NOM STATEMENT

1. Todas las instrucciones de seguridad y operación deberán ser leídas antes de que el aparato eléctrico sea operado.
2. Las instrucciones de seguridad y operación deberán ser guardadas para referencia futura.
3. Todas las advertencias en el aparato eléctrico y en sus instrucciones de operación deben ser respetadas.
4. Todas las instrucciones de operación y uso deben ser seguidas.
5. El aparato eléctrico no deberá ser usado cerca del agua—por ejemplo, cerca de la tina de baño, lavabo, sótano mojado o cerca de una alberca, etc.
6. El aparato eléctrico debe ser usado únicamente con carritos o pedestales que sean recomendados por el fabricante.
7. El aparato eléctrico debe ser montado a la pared o al techo sólo como sea recomendado por el fabricante.
8. Servicio—El usuario no debe intentar dar servicio al equipo eléctrico más allá a lo descrito en las instrucciones de operación. Todo otro servicio deberá ser referido a personal de servicio calificado.
9. El aparato eléctrico debe ser situado de tal manera que su posición no interfiera su uso. La colocación del aparato eléctrico sobre una cama, sofá, alfombra o superficie similar puede bloquea la ventilación, no se debe colocar en libreros o gabinetes que impidan el flujo de aire por los orificios de ventilación.
10. El equipo eléctrico deber ser situado fuera del alcance de fuentes de calor como radiadores, registros de calor, estufas u otros aparatos (incluyendo amplificadores) que producen calor.
11. El aparato eléctrico deberá ser conectado a una fuente de poder sólo del tipo descrito en el instructivo de operación, o como se indique en el aparato.
12. Precaución debe ser tomada de tal manera que la tierra física y la polarización del equipo no sea eliminada.
13. Los cables de la fuente de poder deben ser guiados de tal manera que no sean pisados ni pellizcados por objetos colocados sobre o contra ellos, poniendo particular atención a los contactos y receptáculos donde salen del aparato.
14. El equipo eléctrico debe ser limpiado únicamente de acuerdo a las recomendaciones del fabricante.
15. En caso de existir, una antena externa deberá ser localizada lejos de las líneas de energía.
16. El cable de corriente deberá ser desconectado del cuando el equipo no sea usado por un largo periodo de tiempo.
17. Cuidado debe ser tomado de tal manera que objetos líquidos no sean derramados sobre la cubierta u orificios de ventilación.
18. Servicio por personal calificado deberá ser provisto cuando:
  - A: El cable de poder o el contacto ha sido dañado; u
  - B: Objetos han caído o líquido ha sido derramado dentro del aparato; o
  - C: El aparato ha sido expuesto a la lluvia; o
  - D: El aparato parece no operar normalmente o muestra un cambio en su desempeño; o
  - E: El aparato ha sido tirado o su cubierta ha sido dañada.



# APPENDIX H. TECH SUPPORT/DISCLAIMERS/TRADEMARKS

## H.1 TECH SUPPORT/CONTACT INFORMATION

Visit [blackbox.com/discover-bb/global-presence](https://blackbox.com/discover-bb/global-presence) for regional technical support and contact information.



## H.2 DISCLAIMERS

Black Box Network Services shall not be liable for damages of any kind, including, but not limited to, punitive, consequential or cost of cover damages, resulting from any errors in the product information or specifications set forth in this document and Black Box Network Services may revise this document at any time without notice.

Images contained in this document are included solely to illustrate how to use the product. Since the product can be customized and/or undergo periodic updates, images in this manual will be representative of, although not necessary identical to, the ones displayed on your screen.

## H.3 TRADEMARKS USED IN THIS MANUAL

Black Box and the Double Diamond logo are registered trademarks of BB Technologies, Inc.

Any other trademarks mentioned in this manual are acknowledged to be the property of the trademark owners.



